

ADVANCED PACKAGE TRAINING
SCAFFOLDING

All information in this document is subject to modification without prior notice. No part of this manual may be reproduced, stored in a database or retrieval system or published, in any form or in any way, electronically, mechanically, by print, photo print, microfilm or any other means without prior written permission from the publisher. SCIA is not responsible for any direct or indirect damage because of imperfections in the documentation and/or the software.

© Copyright 2022 SCIA nv. All rights reserved.

Table of Contents

Table of Contents	3
Introduction	5
Chapter 1: Modelling the structure	6
1.1. General	6
1.2. Project data	7
1.3. Materials	8
1.4. Cross-sections	9
1.5. Structure	10
1.6. Model data	16
1.6.1. Supports.....	16
1.6.2. Hinges on beams	18
1.6.3. Diagonals	22
1.7. Connect and check	25
Chapter 2: Loads	26
2.1. Load cases	26
2.1.1. LC1 – self-weight	27
2.1.2. LC2 – service load, service condition	27
2.1.3. LC3 – service load, out of service condition	27
2.1.4. LC4 – maximum wind load, parallel to façade.....	28
2.1.5. LC5 – maximum wind load, perpendicular to façade.....	28
2.1.6. LC6 – working wind load, parallel to façade	28
2.1.7. LC7 – working wind load perpendicular to façade.....	29
2.2. Linear combinations	29
2.3. Stability combinations	30
2.4. Nonlinear combinations	30
Chapter 3: Analysis & results	31
3.1. Linear analysis	34
3.1.1. Bill of material	34
3.2. Stability analysis	35
3.3. Nonlinear analysis	37
3.3.1. Global frame imperfection φ	37
3.3.2. Initial bow imperfection e_0	40
3.3.3. Second order calculation	41
Chapter 4: Checks	44
4.1. Member check	44
4.1.1. SLS check.....	44
4.1.2. ULS check.....	46

4.2. Coupler check	49
4.2.1. General couplers	50
4.2.2. Manufacturer couplers	51
Chapter 5: Reporting	59
5.1. Engineering report	59
5.2. Pictures	59
Annex A: Characteristic values of the resistances for couplers	60
Annex B: Service loads according to EN 12811-1	62
Annex C: Wind loads	64
Annex D: Stability analysis	66
Linear Stability	66
Nonlinear Stability	69
Buckling shape	71
References and literature	75

Introduction

This course has been made for the scaffolding package of SCIA Engineer. In this package the following modules are included:

Module (sen)	Description
sen.00	1D member modeller
	Productivity toolbox
	Linear statics 2D
	Linear statics 3D
	Bridge Combinations & Design EN
	Surface load generators
sen.01	Planar 2D members
	Curved 2D members
	Cut-outs of 2D members
sens.00	Tension only members
	Pressure only support of soil
	Nonlinear springs, gaps
	Geometrical nonlinear of frames
sens.01	Stability analysis of frames
	Stability analysis of surfaces
sens.02	Plastic analysis of steel structures
	Pressure only on surfaces
	Plastic analysis for surface members
	Friction springs
sens.03	Advanced cable analysis
	Nonlinear stability analysis
	Membrane elements
sensd.01.en	Steel code check – EN 1993-1-1
	Scaffolding checks - EN 12811-1
sendt.01	General arrangement drawings

Below you can find an image of the workspace of SCIA Engineer and where to find the different components.

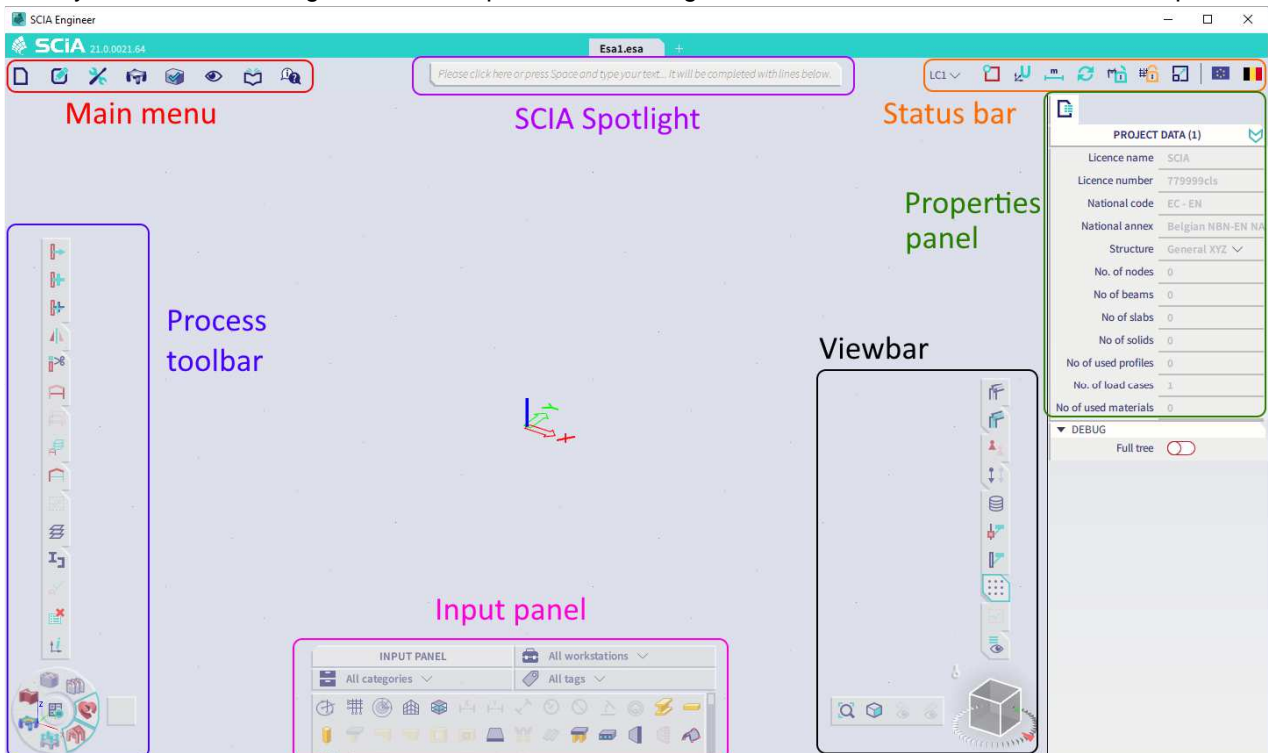

Chapter 1: Modelling the structure

1.1. General

The objective of this manual is to show a way of modelling a scaffolding (class 3) by using SCIA Engineer. In this manual a simple example is elaborated.

The following steel scaffolding will be treated in this course:

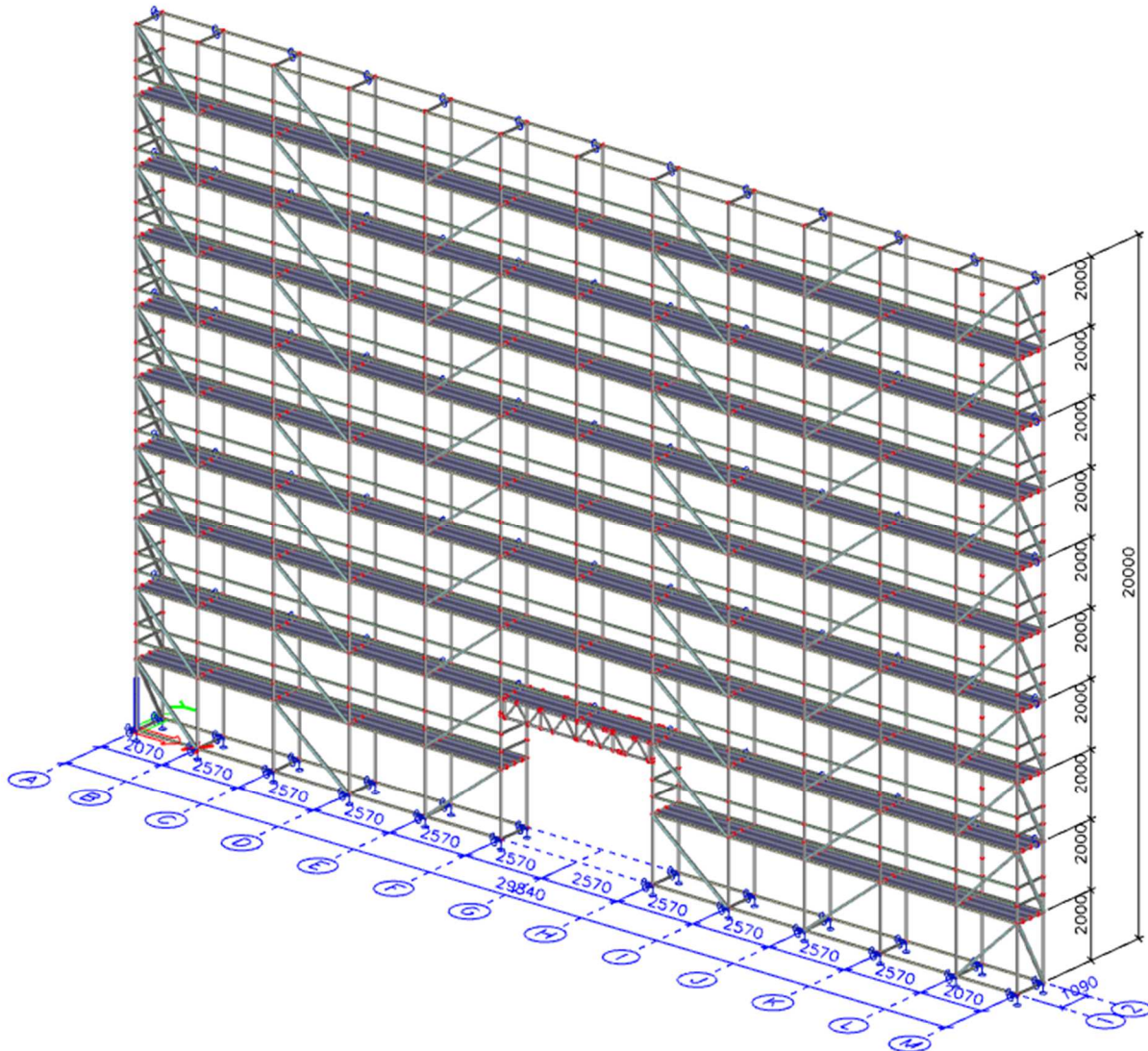

We will use a system of Layher in this example. On the website of Layher, documentation about their system can be found and downloaded: <https://www.layher.nl/en/Documentation>

Of course, other scaffolding systems are possible with SCIA Engineer as well.

Now you have the choice to start from scratch or to start from a template file.

To save time for later projects, it can help to work with a **template file**, where you have already defined several things, such as:

- **project data;**
- **national annex parameters;**
- **materials;**
- **cross-sections;**
- **hinge types;**
- **load cases and combinations** (linear, nonlinear, stability).

1.2. Project data

When starting a new project, the following project data are chosen:

- **Structure:** General XYZ (or Frame XYZ)
- **Material:** steel S 235 and timber C14
- **National Code:** EC - EN
- **National Annex:** Belgian NBN-EN NA

The screenshot shows the 'Project data' dialog box with the 'Basic data' tab selected. The 'DATA' section contains the following fields: Name: Scaffolding training, Part: -, Description: Scaffold, Author: BV, Date: 05.01.2022. The 'MATERIAL' section has checkboxes for Concrete, Steel (checked), Masonry, Aluminium, Timber (checked), Steel fibre concrete, and Other. Below this, the 'CODE' section shows National Code: EC - EN and National annex: Belgian NBN-EN NA. At the bottom, there are 'OK' and 'Cancel' buttons.

Following functionalities should also be ticked on:

- **Property modifiers**
- **Nonlinearity** (+ all options for nonlinearity on the right-hand side: **Beam local nonlinearity**, **Support nonlinearity/basic soil spring**, **Initial imperfections**, **Geometrical nonlinearity** & **Friction support/soil spring**)
- **Stability**
- **Steel > Scaffolding** (or **Aluminium > Scaffolding** if you would model with material aluminium)

The screenshot shows the 'Project data' dialog box with the 'Functionality' tab selected. The 'GENERAL' section has checkboxes for Property modifiers, Model modifiers, Parametric input, Climatic loads, Mobile loads, Dynamics, Stability, Nonlinearity, Structural model, IFC properties, Prestressing, Bridge design, and Excel checks. The 'DETAILED' section has a 'Nonlinearity' group with checkboxes for Beam local nonlinearity, Support nonlinearity/basic soil s, Initial imperfections, Geometrical nonlinearity, General plasticity, Compression-only 2D members, Cables, Friction support/Soil spring, and Membrane elements. There is also a 'Subsoil' group and a 'Steel' group with checkboxes for Plastic hinge analysis, Fire resistance checks, Steel connections, and Scaffolding. At the bottom, there are 'OK' and 'Cancel' buttons.

On the **Actions** tab you can deactivate the automatic code combinations option since specific combinations for scaffolding structures will be created:

The screenshot shows the 'CODE COMBINATIONS' dialog box. It has a checkbox labeled 'Automatic' which is unchecked, and a European Union flag icon to its right.

Note: you can change project settings or functionalities afterwards via **Menu bar > File > Project settings**.

1.3. Materials

You can open the materials library via **Menu bar > Libraries > Materials**.

For the material, S 235 is generally used. For the standards you could create a copy of the S 235 material with a higher self-weight to consider the additional weight of the rosettes.

According to the Zulassung of Layher (Z-8.22-64) you can calculate with a yield strength of 320 MPa for the S 235 material (for the cross-section RO48.3X3.2, so not for the diagonals/bracings with thickness 2.3 mm), so you can change this in the material properties of the material:

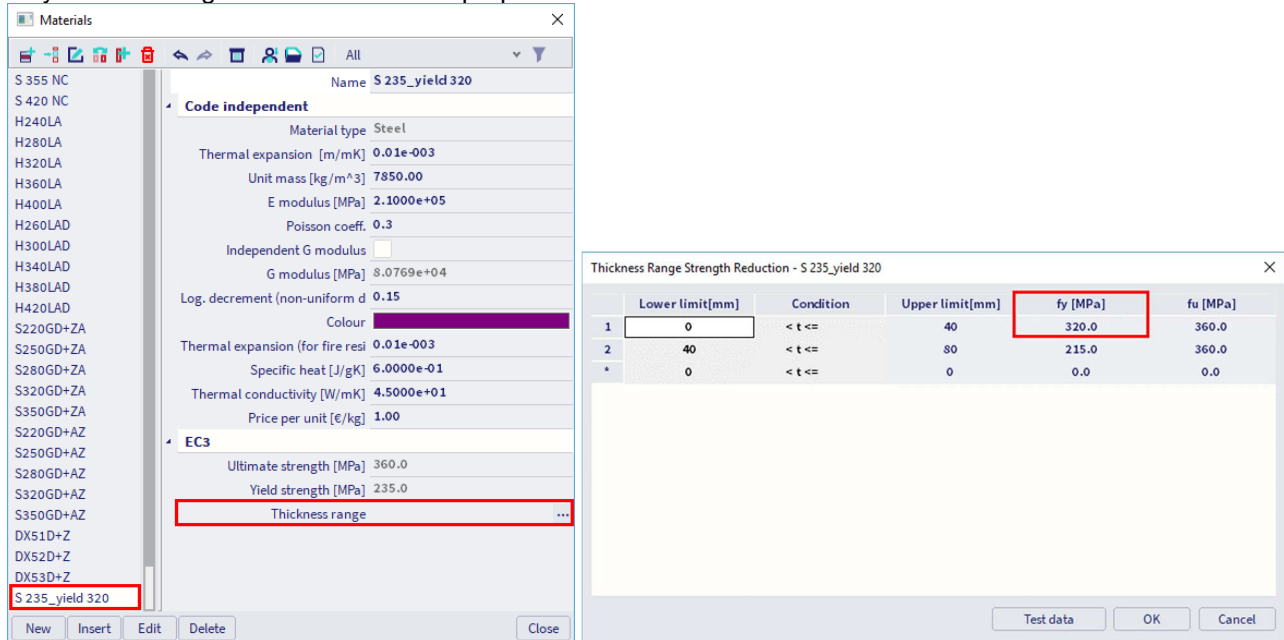

Floorboards and toeboards can also be inserted as members. The average weight of these elements differs from the weight of material S 235 (due to holes in these elements, another thickness of the elements, ...). That is why it is chosen to insert an additional material in SCIA Engineer, in which the weight will be adapted. This weight can be determined as shown below.

A distinction is made between floorboards of 19 cm and 32 cm. For each of them an average weight is calculated.

Name	Weight [kg]	Length [m]	[kg/m]	Average
Floorboard 32/307	23.2	3.07	7.56	8.20 kg/m
Floorboard 32/257	19.0	2.57	7.39	
Floorboard 32/207	15.7	2.07	7.58	
Floorboard 32/157	12.2	1.57	7.77	
Floorboard 32/140	10.8	1.40	7.71	
Floorboard 32/109	10.4	1.09	9.54	
Floorboard 32/73	7.2	0.73	9.86	
Floorboard 19/307	18.2	3.07	5.93	6.18 kg/m
Floorboard 19/257	15.5	2.57	6.03	
Floorboard 19/207	12.7	2.07	6.14	
Floorboard 19/157	10.0	1.57	6.37	
Floorboard 19/109	7.0	1.09	6.42	
Toe board 15/307	6.3	3.07	2.05	2.32 kg/m
Toe board 15/257	5.7	2.57	2.22	
Toe board 15/207	4.3	2.07	2.08	
Toe board 15/157	3.5	1.57	2.23	
Toe board 15/109	2.5	1.09	2.29	
Toe board 15/73	1.5	0.73	2.05	
Toe board 15/30	1.0	0.30	3.33	

It is assumed that the (steel) floorboards have a thickness of 4 cm and the (timber) toeboards have a thickness of 2 cm and height of 15 cm. The weights of the floorboards and toeboards are:

- Floorboards 32 cm: $\rho = \frac{8.20 \text{ kg/m}}{0.32 \text{ m} \cdot 0.04 \text{ m}} = 640.6 \text{ kg/m}^3$
- Toeboards 15 cm: $\rho = \frac{2.32 \text{ kg/m}}{0.15 \text{ m} \cdot 0.02 \text{ m}} = 766.7 \text{ kg/m}^3$

Note: in this example we consider a thickness of 4 cm for the floorboards to consider them as stiff elements. Therefore, we shouldn't perform a deflection check on these floorboards (the supplier should have design tables for this).

1.4. Cross-sections

We can open the cross-section dialog via **Menu bar > Libraries > Cross sections**. In our example we will use following cross-sections from the **Profile Library**:

Name	Cross section	Material
Standard	RO48.3X3.2	S 235-fy320
Ledger	RO48.3X3.2	S 235-fy320
Guardrail	RO48.3X3.2	S 235-fy320
Bracing	RO48.3X2.3	S 235
Floorboard – 0.32 m	RECT (40; 320)	FB 0.32
Toeboard – 0.15 m	RECT (150; 20)	TB 0.15
Diagonal lattice girder	RRO30X20X2K	S 235
Beam lattice girder	RO48.3X3.2	S 235-fy320

Note: the cross-sections **Diagonal lattice girder** and **Beam lattice girder** does not have to be created if we will add these elements with a user block.

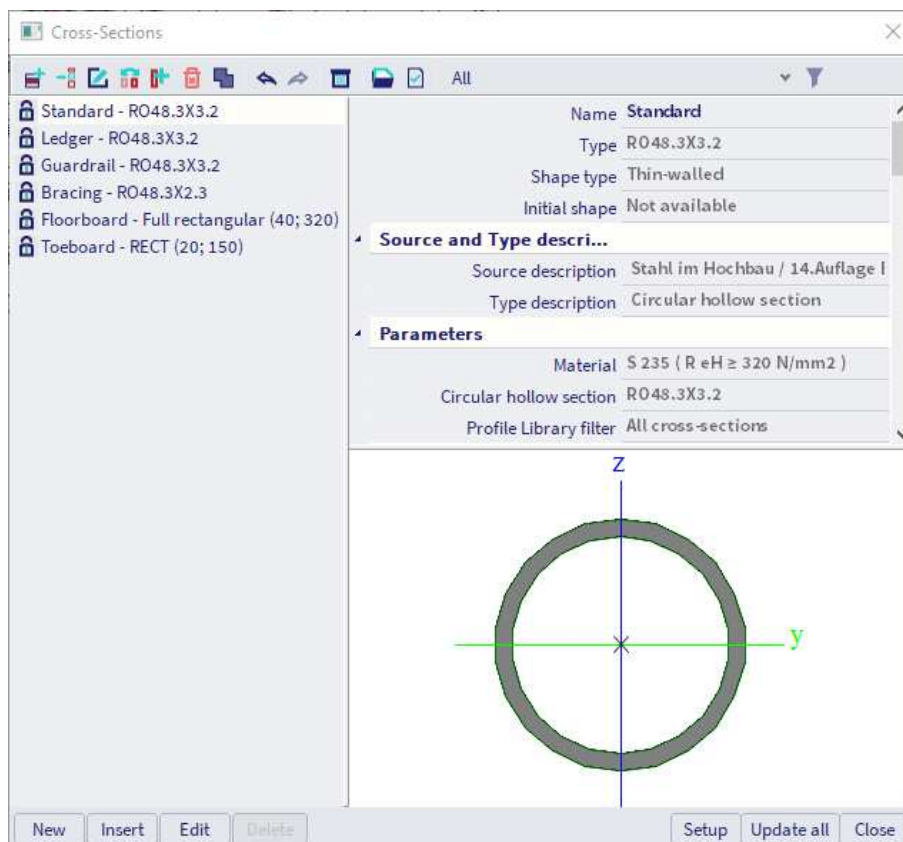

In you want to use a cross-section which is not in the profile library, you can use the group **Thin-walled geometric**.

If also this group does not contain your profile shape, you can use the **General** group to create a section by yourself (for this you need the module sen.05).

1.5. Structure

First a line grid (2D or 3D) can be added to the model. When adding elements, the line grid can be used to snap to.

It could be practical to use layers (**Menu bar > Libraries > Layers**), which can help you later to quickly select a certain group of elements:



Then the elements can be added to the model. You can find the 1D members in the input panel as functions **1D Member, Beam** and **Column (Input panel > Workstation Structure > Category 1D Members)**.

Via **ALT and right-mouse click** you can use the **Marking menu** (available in the new interface since SCIA21.1) to quickly launch the 1D Member or Column command in the Model branch.

You can make use of the **Modify** commands such as **Copy** and **Multicopy** to quickly create additional levels of the structure. You can use the **Marking menu** again to quickly launch the Copy or Multicopy command in the Modify branch:



If you quickly want to edit some parameters (node coordinates, members names, load values, ...), it could be practical to use the **Input table** (available in the new interface since SCIA21.1) via **Menu bar > Tools > Input table**.

A second way of modelling the structure is by making use of **user blocks**. In that way you create only once a block that you want to reuse and each time you need it, you can load it into your model.

The folder, where the user blocks should be stored, can be found through **Menu bar > View > Global UI settings > tab Templates & directories > Show directories for 'User block libraries'**:

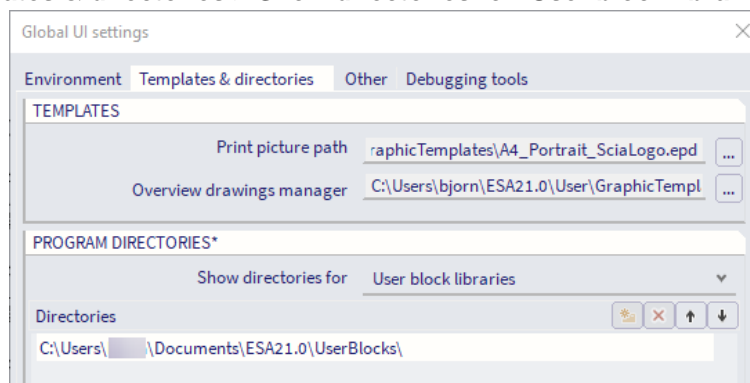

Then you can import the user block with **Input panel > Workstation Structure > Category Import & Blocks > User blocks**:

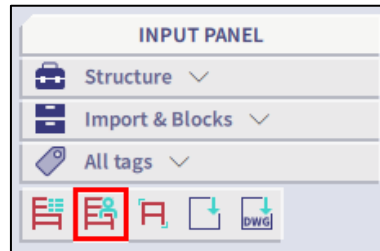

It is also possible to **import** directly from CAD software. To import it you must go to **Menu bar > File > Open from** and choose the desired format (**XML file, Revit file, Tekla file, IFC file, ...**):

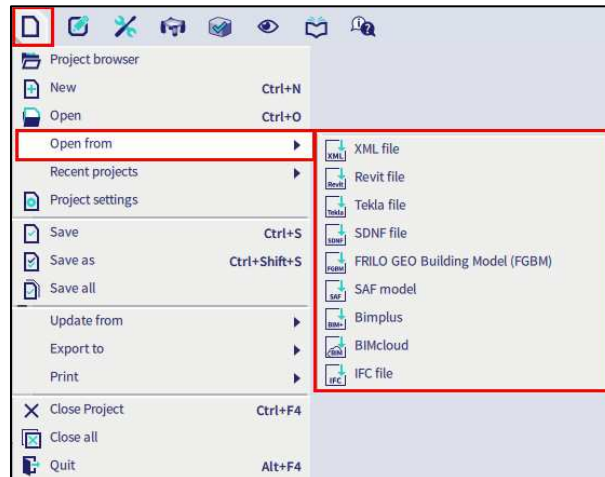

You can also import with the direct links with Revit or Tekla Structures. Even IFC import can be used, but then the model should be cleaned up (align, ...) with the BIM toolbox because with the IFC format we are importing a structural model, which should be converted to an analytical model.

It is also possible to import a DWG or DXF file with **Input panel > Workstation Structure > Category Import & Blocks > Import DWG, DXF, VRML97**. You can import the lines and assign the elements later or you can directly convert the lines into beams.

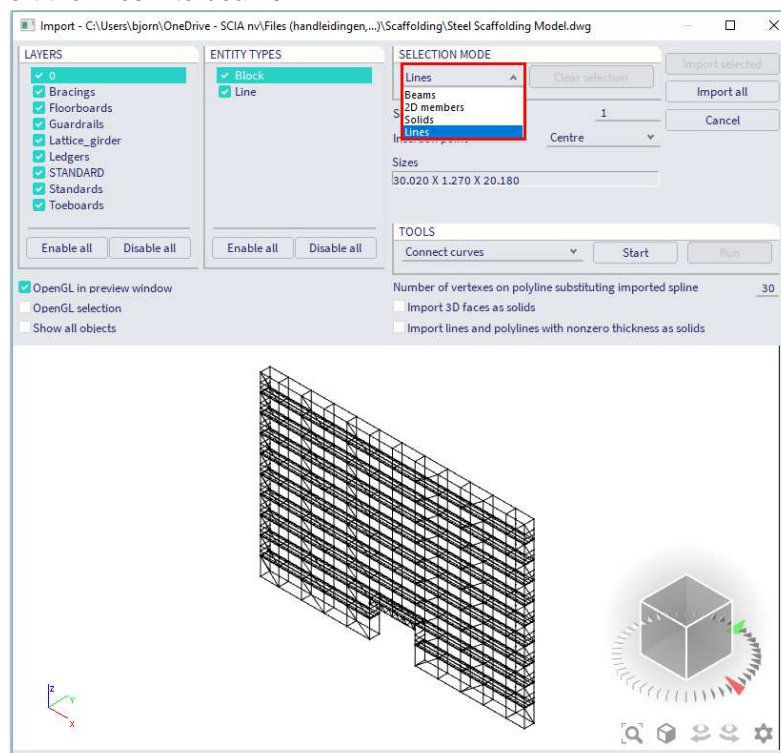

For our structure we will start with adding a 2D line grid. You can go to **Input panel > Workstation Structure > Category Grids & Storeys > Rectangular grid**. We create a grid of 2.07 + 10*2.57 + 2.07 in X direction and 1.09 m in Y direction:

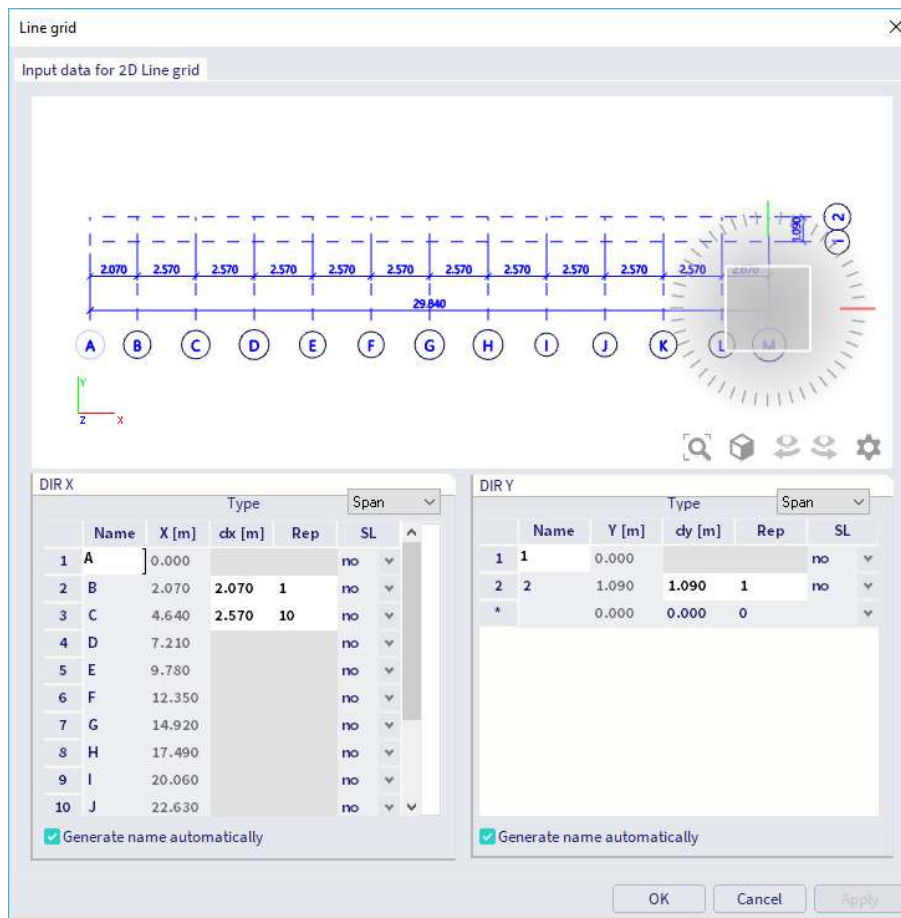

Then we can use the snapping setting **Line grid** (you can find the snapping settings in the status bar) to add the **standards** as column (define the columns as type 'column (100)', 'gable column (70)' or 'secondary column (60)', so the coupler check can be performed later), the **ledgers** as beam and the **diagonals** as member. The standards have a length of 2 m and the ledgers have lengths of 1.09 m, 2.07 m and 2.57 m.

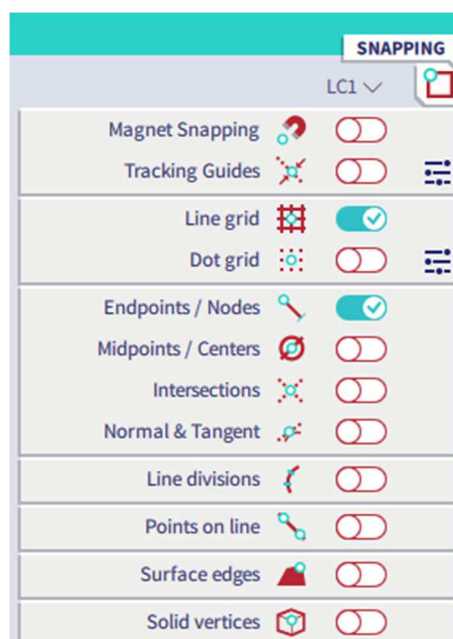

Define the **diagonals** as type 'wall bracing (0)' or 'truss diagonal (90)' (so the coupler check can be performed later). The diagonals are entered with an **eccentricity** e_y (in the y direction) of 48.3 mm (width of the profile). This value should be given in positive or negative, depending on the direction of the diagonal. This way the wind bracings are truly on top of the other members and not in between.

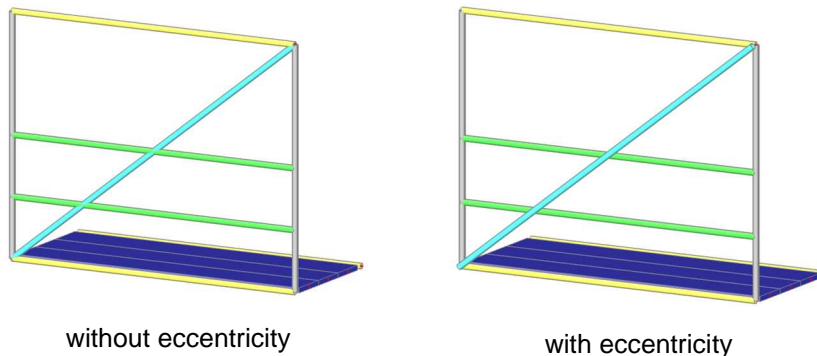

without eccentricity

with eccentricity

For a ledger of 1.09 m, we will put the floorboards (with a width of 0.32 m) on 0.225 m from the edges of the ledger and with 0.32 m between each other:

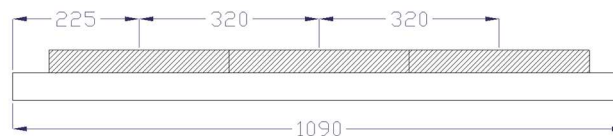

Therefore, the snapping settings **Midpoints / Centers** and **Points on line** could be used:

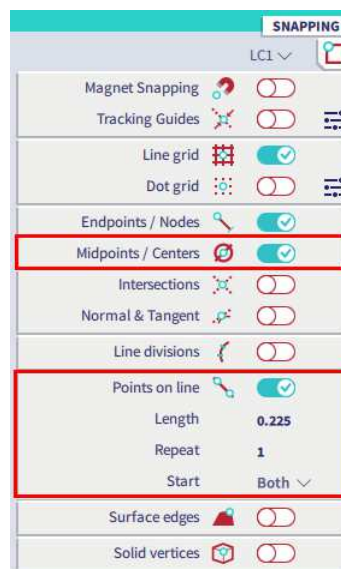

Now we have added the floorboards on the first level and we copy the ledgers at the 2 m level three times: 2 times over a distance of 0.5 m in Z direction (for the guardrails) and 1 time over a distance of 0.075 m in Z direction (for the toeboards). Then we change the properties of these copied elements to the correct cross-section and layer.

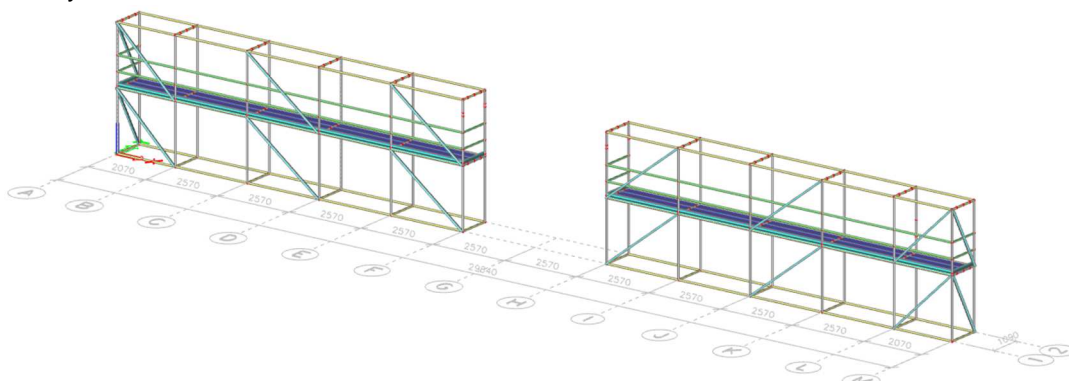

For the lattice girder we could make use of a user block (if we have created the block before):

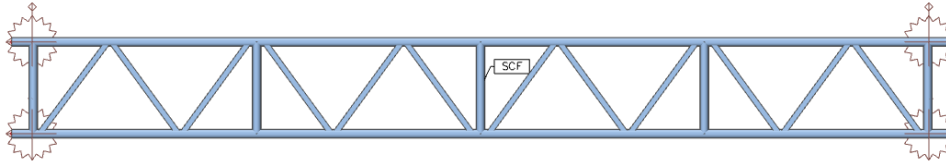

The folder, where the user blocks should be stored, can be found through **Menu bar > View > Global UI settings > tab Templates & directories > Show directories for 'User block libraries'**.

Then you can import the user block with **Input panel > Workstation Structure > Category Import & Blocks > User blocks** and select the block from the User library.

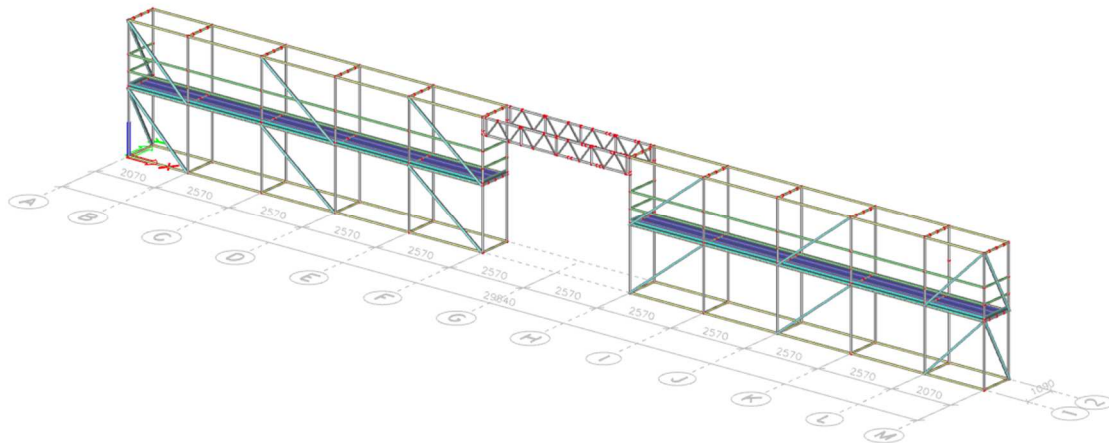
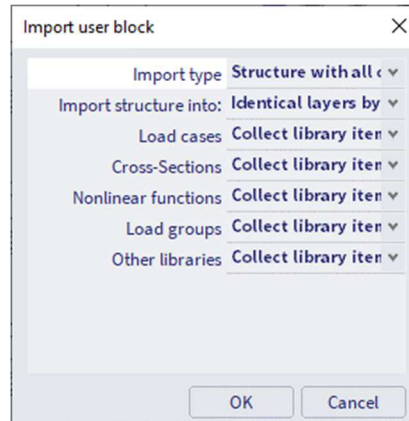

Note: in our example the lattice girder will be attached to the rosettes of the standards. There are also systems of lattice girders which connect with right angle couplers to the standards. In that case you will give the lattice girder an eccentricity and you can connect them to the standards by using a Cross-link at each connection point (Input panel > Workstation Structure > Category Boundary conditions > Crosslink).

Now you can use **modify (Copy, Multicopy, ...)** and **select (Menu bar > View > Visibility** or right-clicking on a property in the property panel and choosing **Expand selection, ...)** commands to quickly model the remaining part of the structure.

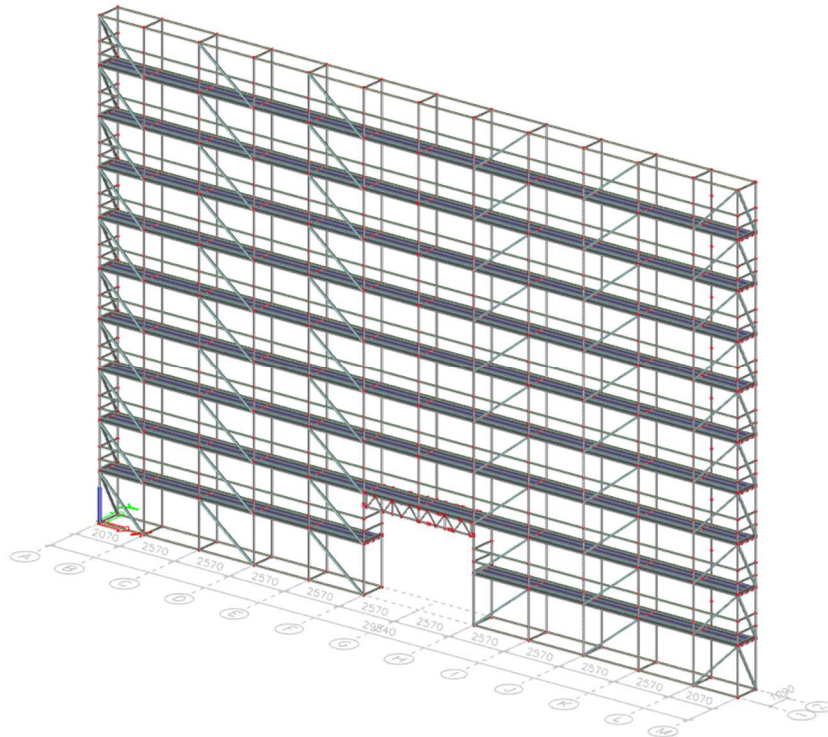

To transfer surface loads to line loads on the beams, we will make use of **load panels (Input panel > Workstation Structure > Category Load Panels > Load with load to 1D & edges)**.

Load panels are entities that are not considered in the FEM analysis. The stiffness is thus not considered in the calculation, but they can redistribute the applied surface load to their edges and intermediate beams.

In our example we will add a load panel for the three sides of the scaffolding (LP1, LP2 and LP3; so not on the side of the wall) and on the top (LP4) and the second top floor (LP5). For the side panels the load will be transferred to all directions (especially when there is a net around the structure). For the floor panels we will transfer in 1 direction (so the load is transferred to the floorboards).

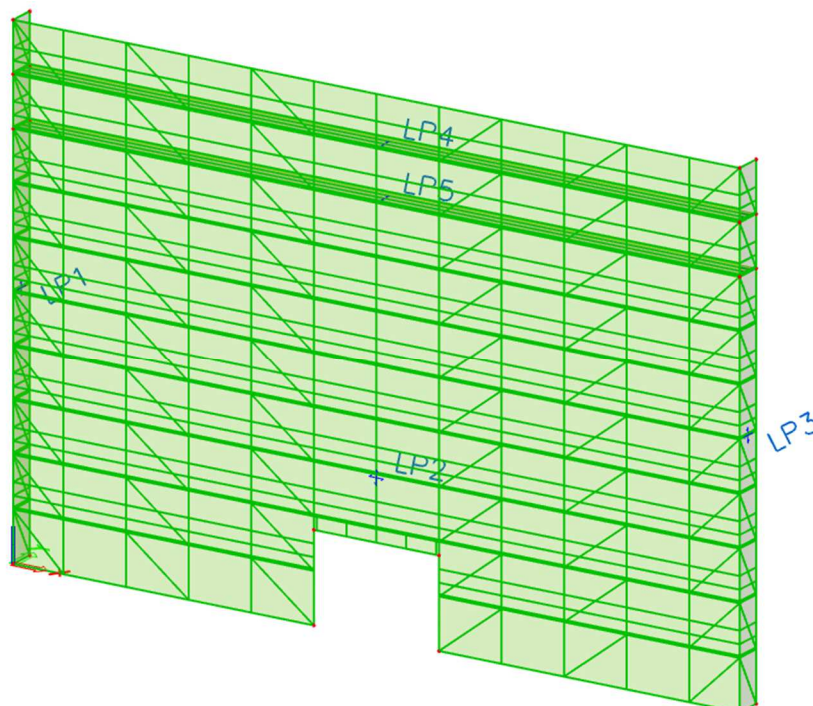

1.6. Model data

Now we will add several types of model data to our model: supports (base jacks and anchors), hinges on beams (couplers and hinges on the floorboards and diagonals) and beam nonlinearities (gaps).

You can find these input data via **Input panel > Workstation Structure > Category Boundary conditions**.

1.6.1. Supports

You can use the **Marking menu** again to quickly launch the **Support In Node** command in the Model branch:



We will add the supports for the **base jacks** (at the bottom nodes of the lowest standards) as nonlinear supports. In the vertical direction these supports can only take pressure and no tension. This is entered in the Z direction with **rigid press only**. The rotations are taken free in all directions.

For the degrees of freedom according to the X and Y displacements, the code EN 12812:2004, Annex B is applied. In this code, **friction coefficients** between various materials are given. If we suppose that the scaffolding is placed on wood, we can see in this code that the maximal and minimal friction coefficient between wood and steel is 1.2 and 0.5. On average a value of 0.85 is adopted, which we will enter in our model.

For **C flex** a large value is taken. This corresponds to a large rigidity of the support in X and Y direction before the friction is exceeded.

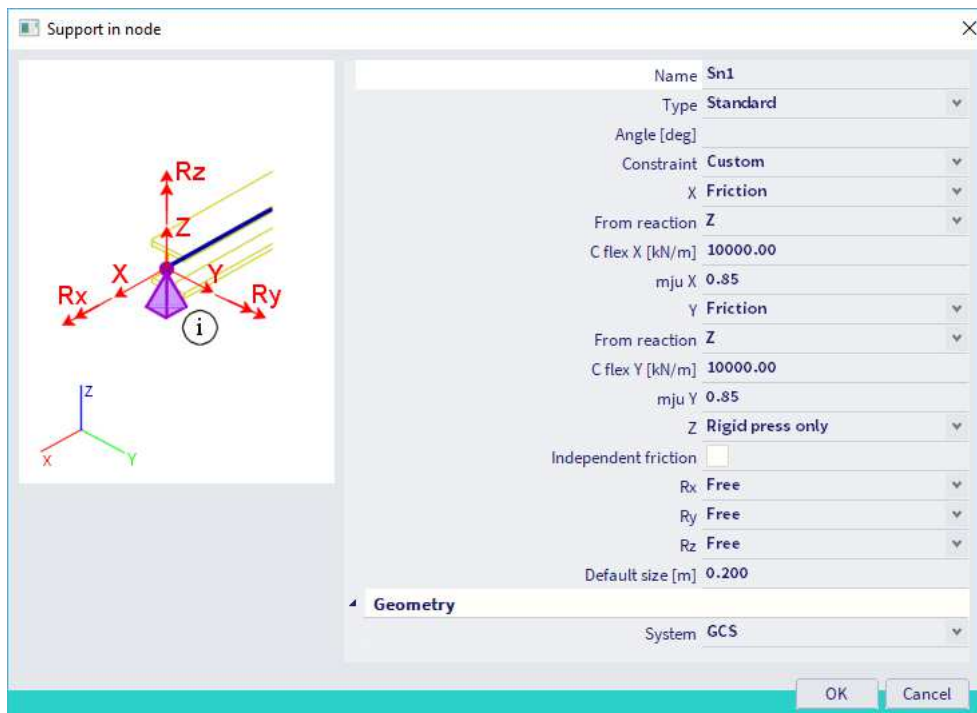

We will also add **anchors** to connect the scaffolding to the wall behind. We will add a row of supports (**only translations in X and Y direction are set as rigid**) at **4 m, 8 m, 12 m, 16 m and 20 m**. For constructions over 20 m high, this needs to be performed every 2 m upward.

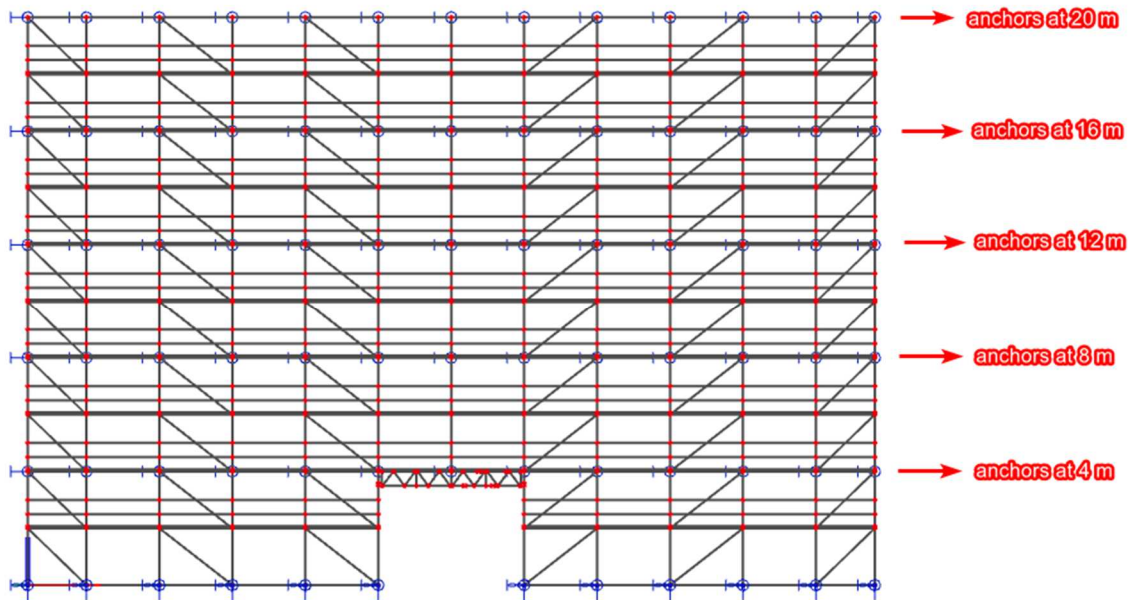
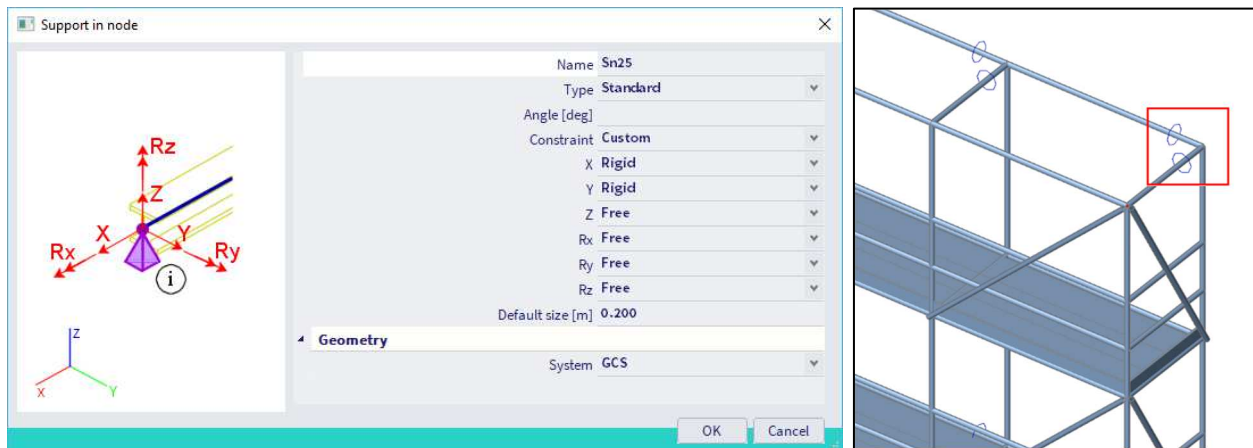

Note: adding nodal supports like this is a simplification of the reality. In reality a tube will be connected to the column (with a crosslink) and at the end of the tube (side of the wall behind) a nodal support as described above could be added.

1.6.2. Hinges on beams

Couplers - general principle

Various coupler types are available in SCIA Engineer. For the different couplers, go to **Menu bar > Libraries > Structure and analysis > Hinge type**.

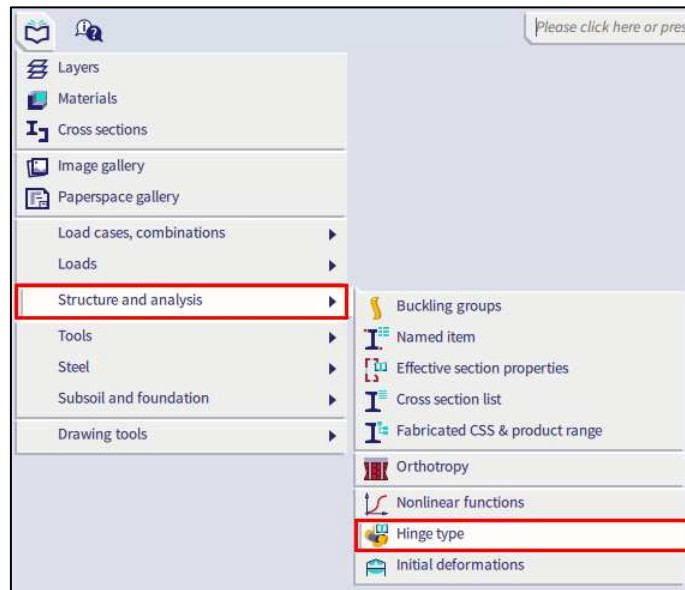

In this **Hinge type** library you can choose following non-manufacturer types (from EN 12811) for the parameter '**Hinge type**':

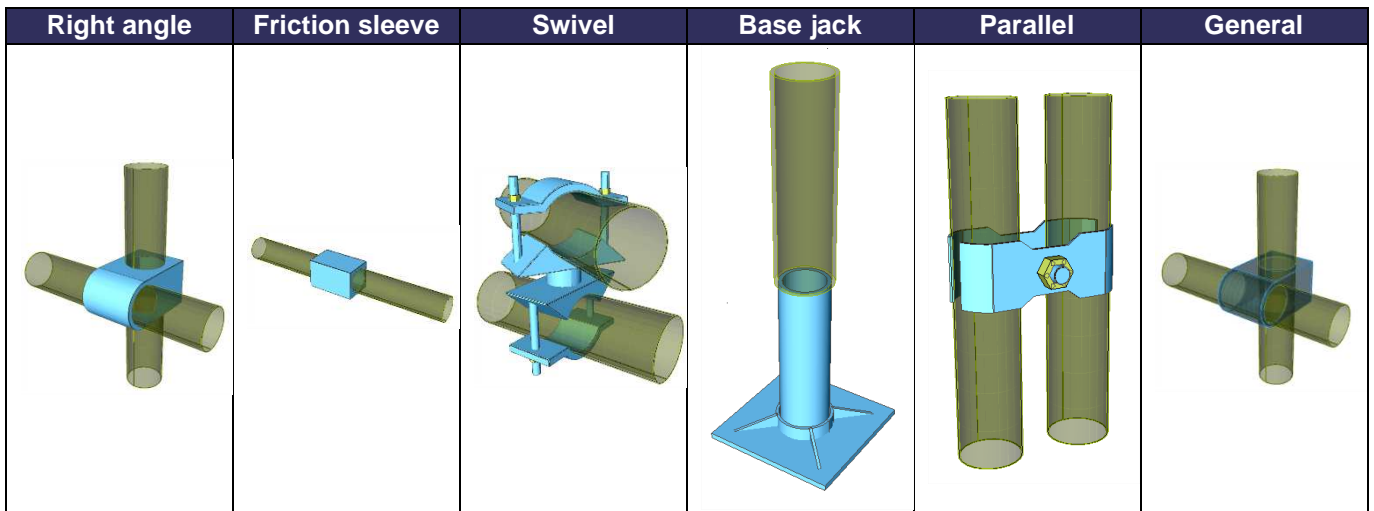

Note: if the functionality **Scaffolding** is not ticked on in Menu bar > File > Project settings > tab Functionality you will not be able to see the hinge type library.

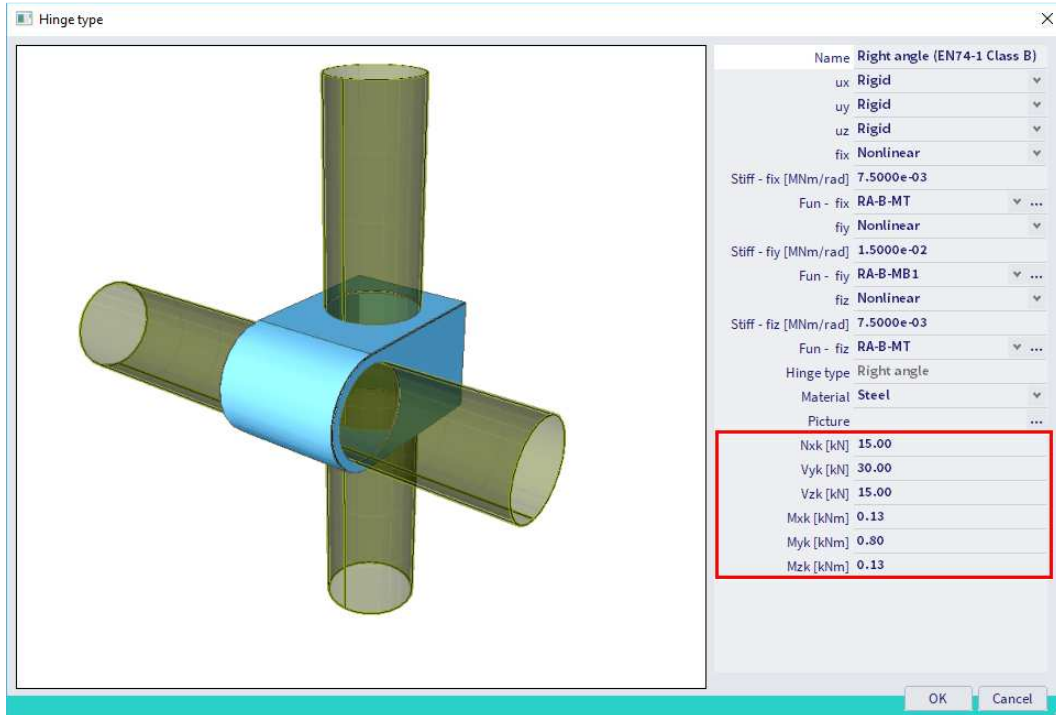

For these couplers, not only the rigidities are entered in a flexible or nonlinear way, but also the maximal allowable forces are defined, as displayed below for the **Right angle** coupler:



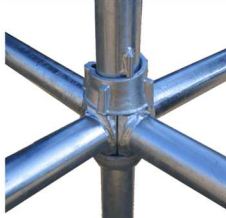

The rigidities and maximal forces are taken from the code EN 12811-1 Annex C. These tables and figures are added in Annex A of this manual.

Couplers of manufacturers in SCIA Engineer

Not only the types that are mentioned in the code are available in SCIA Engineer. You can also find couplers from manufacturers in the library: Cuplock, Layher and Catari (the Catari coupler is available since SCIA Engineer 20):

Cuplok	Catari US
	
<p>Name Cuplok</p> <ul style="list-style-type: none"> ux Nonlinear Stiff - ux [MN/m] 4.3640e+01 Fun - ux Cuplok-N1 uy Rigid uz Rigid fix Nonlinear Stiff - fix [MNm/rad] 1.8270e-02 Fun - fix Cuplok-Mx1 fy Nonlinear Stiff - fiy [MNm/rad] 6.5000e-02 Fun - fiy Cuplok-My1 fz Flexible Stiff - fiz [MNm/rad] 2.5000e-03 Hinge type Cuplok Material Steel Picture ... Nxk [kN] 54.12 Vyk [kN] 0.00 Vzk up [kN] 18.15 Vzk down [kN] 21.78 Mxk [kNm] 1.04 Myk [kNm] 2.29 Mzk [kNm] 0.00 	<p>Name Catari (Universal System US)</p> <ul style="list-style-type: none"> ux Rigid uy Rigid uz Rigid fix Free fy Nonlinear Stiff - fiy [MNm/rad] 3.8950e-02 Fun - fiy Catari US - My fz Free Hinge type Catari US Material Steel Picture ... Nxk+ [kN] 47.20 Vyk [kN] 9.10 Vzk [kN] 19.90 Mxk [kNm] 0.00 Myk+ [kNm] 1.39 Myk- [kNm] 1.30 Mzk [kNm] 0.00

Layher Variante K2000+	Layher Variante II	Layher Variante LW
		
<p>Name Layher (Variante K2000+)</p> <ul style="list-style-type: none"> ux Rigid uy Flexible Stiff - uy [MN/m] 4.8500e+00 uz Rigid fix Nonlinear Stiff - fix [MNm/rad] 1.3876e-03 Fun - fix Layher K2000+ - Mx2 fy Nonlinear Stiff - fiy [MNm/rad] 7.6680e-02 Fun - fiy Layher K2000+ - My2 fz Flexible Stiff - fiz [MNm/rad] 5.1000e-03 Hinge type Layher (Variante K2000+) Material Steel Picture ... Nxk [kN] 34.10 Vyk [kN] 11.00 Vzk [kN] 29.04 Mxk [kNm] 0.58 Myk [kNm] 1.11 Mzk [kNm] 0.41 	<p>Name Layher (Variante II)</p> <ul style="list-style-type: none"> ux Rigid uy Flexible Stiff - uy [MN/m] 4.8500e+00 uz Rigid fix Free fy Nonlinear Stiff - fiy [MNm/rad] 6.5820e-02 Fun - fiy Layher II - My1 fz Flexible Stiff - fiz [MNm/rad] 5.1000e-03 Hinge type Layher (Variante II) Material Steel Picture ... Nxk [kN] 24.97 Vyk [kN] 7.37 Vzk [kN] 19.14 Mxk [kNm] 0.00 Myk [kNm] 0.75 Mzk [kNm] 0.41 	<p>Name Layher (Variante LW)</p> <ul style="list-style-type: none"> ux Rigid uy Nonlinear Stiff - uy [MN/m] 8.3330e-01 Fun - uy Layher Variante LW - Vy uz Rigid fix Nonlinear Stiff - fix [MNm/rad] 2.4620e-03 Fun - fix Layher Variante LW - Mx fy Nonlinear Stiff - fiy [MNm/rad] 1.1560e-01 Fun - fiy Layher Variante LW - My fz Nonlinear Stiff - fiz [MNm/rad] 1.0000e-02 Fun - fiz Layher Variante LW - Mz Hinge type Layher (Variante LW) Material Steel Picture ... Nxk [kN] 38.61 Vyk [kN] 18.26 Vzk [kN] 34.87 Mxk [kNm] 0.58 Myk [kNm] 1.32 Mzk [kNm] 0.44

Note: 'Layher Variante LW' was called 'Layher Variante HS' before SCIA Engineer 20.

As you can see each of these couplers has its specific nonlinear functions and maximal forces, which are stored in the SCIA database and which are automatically assigned when you choose the desired coupler type.

You have to select the appropriate material (steel or aluminium), because this will have an influence on the safety factor of the coupler: when choosing for the material steel, the safety factor will be taken out of the National Annex of EN 1993-1-1, while for aluminium the National Annex of EN 1999-1-1 is used.

In our example, a coupler of **Layher** is being adopted (type **Variante K2000+**). The values for N_{xk} , V_{yk} , V_{zk} , M_{xk} , M_{yk} and M_{zk} are automatically filled in (taken from Zulassung Z-8.22-64). The equation for the rotation is given by φ_d [rad] = $M/(9140 - 73.6M)$ and is presented by following curve:

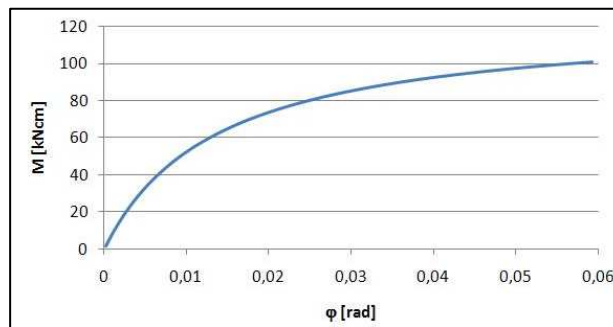

According to this curve, a nonlinear function is linked automatically to the coupler:

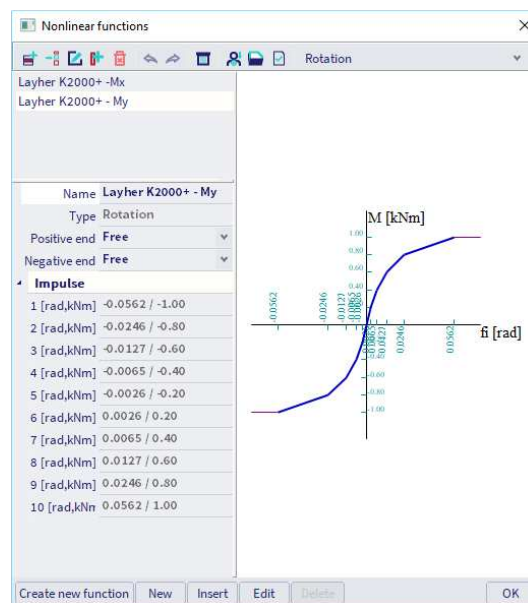

Note: if you want to add other types of (manufacturer) couplers to the library, you can create the nonlinear functions by yourself. In order to do this easily, you can use the Excel file 'gvSEN NonLinear Function Input - rev01' from the SCIA garage (<https://resources.scia.net/en/garage/sciagarage.htm>). You also have to fill in the maximal allowable forces in the hinge type window.

We will add as hinges the library item **Layher Variante K2000+** to both extremities of the **ledgers** and **guardrails** in our model.

For the connection between two **standards**, we will consider that the standards are **rigidly** connected. The overlap length between two columns is 200 mm > 150 mm, so the columns are rigid in the x direction. Moreover, the margin between two columns is 3.9 mm (= 48.3 mm – 2 x 3.2 mm – 38 mm), so this is less than 4 mm. Because of this, also the degrees of freedom in the y and z directions are rigid. This is also mentioned in the code EN 12811-1 (the connection column - column can be considered rigid in the modelling, a hinge will not be entered at the extremities on the standard).

For the connection between the **floorboards** and the **ledgers**, you can consider the **rotation around y axis** as **free** (and all other degrees of freedom as rigid). For the connection between the **toeboards** and the **standards**, you can consider the **rotation around z axis** as **free** or as **flexible** with a certain stiffness (and all other degrees of freedom as rigid).

The boundary conditions on the diagonals will be discussed in the next chapter.

1.6.3. Diagonals

The Zulassung of Layher (Z-8.22-64 Layher AR or Z-8.22.939 Layher LW) describes how to consider the spring stiffness for the diagonals:

"When verifying scaffolding, the vertical diagonals including their connections must be taken into account with a displacement spring with the design values according to Table 7, regardless of the execution."

Tabelle 7: Bemessungswerte der Steifigkeit der Wegfeder der Vertikaldiagonalen

Feldhöhe H [mm]	Feldlänge L [mm]	Stablänge [mm]	Bemessungswert der Steifigkeit der Wegfeder $c_{v,d}$ [kN/cm]	
			Beanspruchung durch Zug-Normalkraft	Beanspruchung durch Druck-Normalkraft
500	732	764	16,0	21,8
	1088	1059	11,5	19,8
	1572	1503	9,5	18,4
	2072	1981	8,6	17,2
	2572	2468	8,2	15,0
	3072	2960	7,9	13,2
1000	732	1155	16,1	20,0
	1088	1368	17,5	21,3
	1572	1734	13,4	19,3
	2072	2162	11,1	16,8
	2572	2616	9,8	14,8
	3072	3084	9,1	12,9
1500	732	1607	14,8	18,1
	1088	1766	16,0	18,9
	1572	2063	17,1	19,0
	2072	2434	14,1	16,7
	2572	2845	12,0	14,4
	3072	3280	10,7	12,5
2000	732	2082	14,0	16,3
	1036	2185	14,8	16,5
	1088	2207	14,9	16,5
	1400	2356	15,6	16,6
	1572	2451	16,0	16,5
	2072	2770	16,7	15,8
	2572	3137	14,4	13,6
	3072	3537	12,6	11,8
2500	4144	4462	10,4	9,1
	6144	6490	9,3	7,9

L, H siehe Anlage A, Seite 4

Together with the information of Table 8 nonlinear functions can be created in SCIA Engineer for each type of diagonal.

Tabelle 8: (Fortsetzung)

H [mm]	L [mm]	Anschlusskopf											
		„K2000+“		„Variante II“		„Variante IB“		„Variante IC“		Lochscheibe			
		„K2000+“	„Variante II“	„K2000+“	„Variante II“	„K2000+“	„Variante II“	„K2000+“	„Variante II“	„K2000+“	„Variante II“		
Druck-Normalkraft $N_{V,Rd}^{(1)}$ [kN]													
500	732	21,1	13,3	---									
	1088	17,2	13,3	---									
	1572	16,1	12,4	6,6	8,4	8,4	6,6	7,8	7,8	6,6	6,6	6,6	6,6
	2072	15,7	12,1	6,6	8,4	8,4	6,6	7,8	7,8	6,6	6,6	6,6	6,6
	2572	15,2	11,9	6,6	8,4	8,4	6,6	7,8	7,8	6,6	6,6	6,6	6,6
3072	11,5	11,2	---										
1000	732	20,0	13,5	---									
	1088	23,1	13,5	---									
	1572	18,7	13,5	6,6	8,4	8,4	6,6	7,8	7,8	6,6	6,6	6,6	
	2072	17,1	13,2	6,6	8,4	8,4	6,6	7,8	7,8	6,6	6,6	6,6	
	2572	14,0	12,7	6,6	8,4	8,4	6,6	7,8	7,8	6,6	6,6	6,6	
3072	10,8	10,5	---										
1500	732	17,8	12,5	---									
	1088	20,4	13,5	---									
	1572	19,3	13,5	6,6	8,4	8,4	6,6	7,8	7,8	6,6	6,6	6,6	
	2072	15,5	13,5	6,6	8,4	8,4	6,6	7,8	7,8	6,6	6,6	6,6	
	2572	12,3	11,9	6,6	8,4	8,4	6,6	7,8	7,8	6,6	6,6	6,6	
3072	9,7	9,6	---										
2000	732	16,6	12,2	6,6	8,4	8,4	6,6	7,8	7,8	6,6	6,6	6,6	
	1036	17,9	12,8	---									
	1088	17,7	12,9	---									
	1400	16,3	13,5	6,6	8,4	8,4	6,6	7,8	7,8	6,6	6,6	6,6	
	1572	15,4	13,5	6,6	8,4	8,4	6,6	7,8	7,8	6,6	6,6	6,6	
	2072	12,8	12,4	6,6	8,4	8,4	6,6	7,8	7,8	6,6	6,6	6,6	
2572	10,5	10,2	---										
3072	8,5	8,3	---										
4144	5,4	5,3	5,3	5,3	5,3	4,1	4,1	4,1	4,1	4,1	4,1	4,1	
2500	6144	2,2	2,1	2,1	2,1	2,1	1,6	1,6	1,6	1,6	1,6	1,6	

L, H siehe Anlage A, Seite 4

Tabelle 8: Beanspruchbarkeiten der Vertikaldiagonalen

H [mm]	L [mm]	Anschlusskopf										
		„K2000+“		„Variante II“		„Variante IB“		„Variante IC“		Lochscheibe		
		„K2000+“	„Variante II“	„K2000+“	„Variante II“	„K2000+“	„Variante II“	„K2000+“	„Variante II“	„K2000+“	„Variante II“	
Zug-Normalkraft $N_{V,Rd}^{(1)}$ [kN]												
500	732	26,2	---									
	1088	25,8	---									
	1572	24,1	13,5	6,6	8,4	8,4	6,6	7,8	7,8	6,6	6,6	6,6
	2072	23,5	13,5	6,6	8,4	8,4	6,6	7,8	7,8	6,6	6,6	6,6
	2572	23,2	13,5	6,6	8,4	8,4	6,6	7,8	7,8	6,6	6,6	6,6
3072	23,1	---										
1000	732	21,7	---									
	1088	24,3	---									
	1572	27,6	13,5	6,6	8,4	8,4	6,6	7,8	7,8	6,6	6,6	6,6
	2072	25,7	13,5	6,6	8,4	8,4	6,6	7,8	7,8	6,6	6,6	6,6
	2572	24,6	13,5	6,6	8,4	8,4	6,6	7,8	7,8	6,6	6,6	6,6
3072	24,1	---										
1500	732	19,8	---									
	1088	22,0	---									
	1572	24,4	13,5	6,6	8,4	8,4	6,6	7,8	7,8	6,6	6,6	6,6
	2072	27,3	13,5	6,6	8,4	8,4	6,6	7,8	7,8	6,6	6,6	6,6
	2572	26,8	13,5	6,6	8,4	8,4	6,6	7,8	7,8	6,6	6,6	6,6
3072	25,6	---										
2000	732	18,0	13,5	6,6	8,4	8,4	6,6	7,8	7,8	6,6	6,6	6,6
	1036	20,8	---									
	1088	21,2	---									
	1400	22,0	13,5	6,6	8,4	8,4	6,6	7,8	7,8	6,6	6,6	6,6
	1572	22,6	13,5	6,6	8,4	8,4	6,6	7,8	7,8	6,6	6,6	6,6
	2072	24,5	13,5	6,6	8,4	8,4	6,6	7,8	7,8	6,6	6,6	6,6
2572	26,7	---										
3072	27,6	---										
4144	25,5	---										
2500	6144	24,7	13,5	6,6	8,4	8,4	6,6	7,8	7,8	6,6	6,6	6,6

For the Layher Allround system with coupler K2000+ the nonlinear function for a diagonal with height 2000 mm and field length 1088 mm would be:

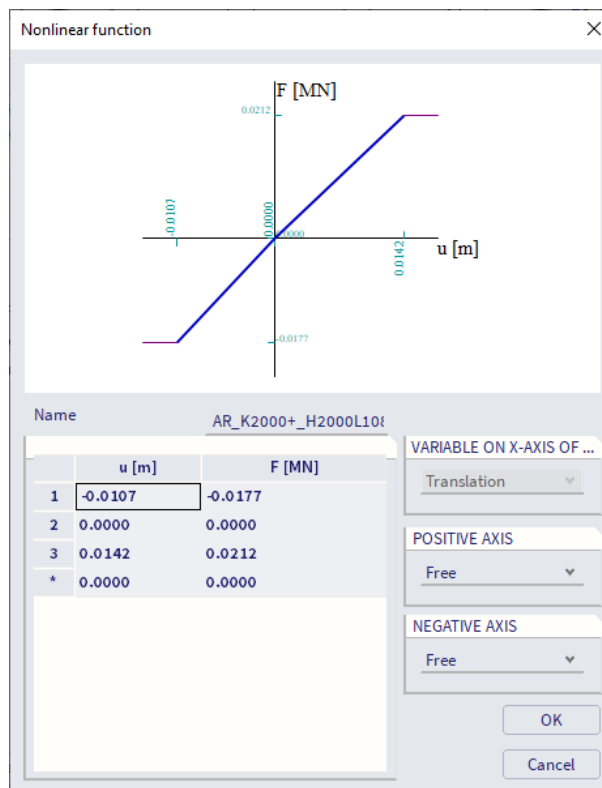

So for the connection between the **standards** and the **diagonals** we can also use Hinge on 1D. In this case you can define the **rotation around y axis** as **free** or as **flexible** with a certain stiffness. There can be a discussion about the rigidity around the z axis. In this example, it is set on rigid, although it cannot be completely considered as rigid. If you want to enter an exact value, you must ask it to the supplier. On one end of the element, the rotation around the x axis and the translations in the x, y and z direction are 'rigid'. On the other end of the element a similar hinge will be added, with ux set as nonlinear function for the specific diagonal.

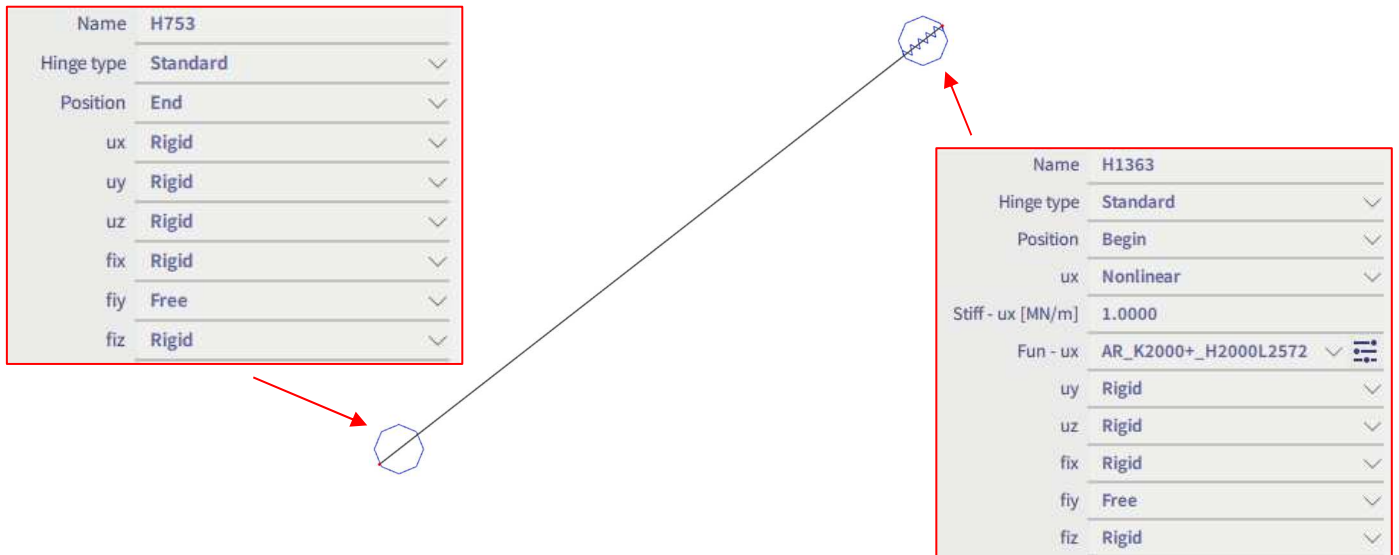

For the analysis the axial stiffness of the diagonal should be infinite since the spring values defined in the Zulassung replace both the stiffness of the diagonal elements and its connections. This can be achieved by using a 1D property modifier (**Input panel > Workstation Structure > Category Boundary conditions > 1D property modifiers**) and applying a correction factor of 10 for Ax of all diagonals.

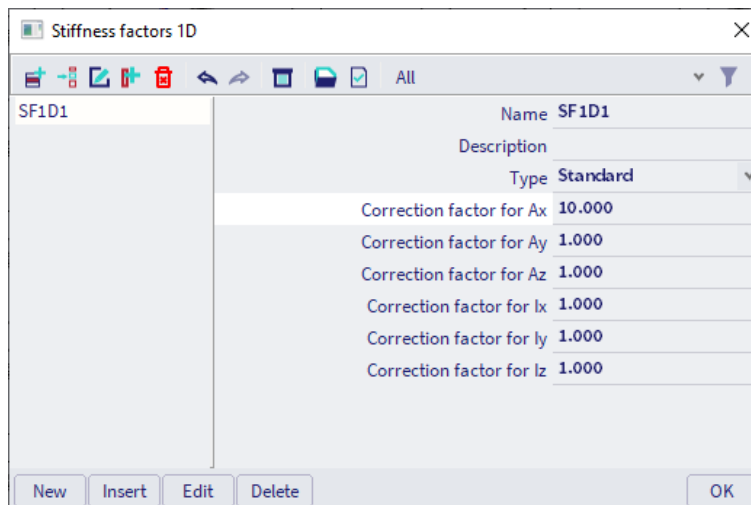

Alternatively diagonals could be modelled via Nonlinearity 1D (**Input panel > Workstation Structure > Category Boundary conditions > Nonlinearity 1D**). Possibilities are:

- Type **Gap**: e.g. a margin of **1 mm**. Note that this could cause issues during the analysis since between 0 and 1 mm displacement there is no stiffness present and the ends of the element.
- Type **Limit force** and as direction **Limit compression**. If the subtype **buckling (results zero)** is chosen, the diagonal will lose its stability and bears no load at all when the limit force is reached. When the subtype plastic **yielding** is used, the diagonal follows the plastic stress-strain diagram when the limit force is reached.

Another alternative is to use a coupler on the connection of the diagonal with the standard (for example Cuplok-N as nonlinear function for ux)

1.7. Connect and check

After modelling the construction, it is recommended to check the input by using the command **Check Structure (Menu bar > Tools > Check structure)**. Through this function the geometry is checked on errors.

After the check, the command **Connect members/nodes (Menu bar > Edit > Modify > Connect members/nodes)** is applied to the entire construction. With this function the different parts are connected to each other. Since version 19.0 it is possible to execute the connect command automatically at the start of the calculation (if you would be working in the default post processing environment).

Chapter 2: Loads

According to EN 12811-1, two combinations should be considered for the structural design of a scaffolding: a **service condition** and an **out of service condition**. The service condition corresponds with the self-weight of the scaffolding, a working load on the scaffolding and a working wind load, while the out of service condition corresponds with the self-weight, a percentage of the working load and the maximum wind load.

2.1. Load cases

There are three main types of loads which need to be considered (according to EN 12811-1, 6.2.1.):

- **Permanent loads:** these shall include the **self-weight** of the scaffolding structure, including all components, such as platforms, fences, fans and other protective structures and any ancillary structures such as hoist towers.
- **Variable loads:** these shall include **service loads** (loading on the working area, loads on the side protection) and **wind loads** and, if appropriate, **snow** and **ice loads**.
- **Accidental loads:** the only load specified in the standard (EN 12811-1, 6.2.5.1) is the **downward loading** on the side protection or guardrails (1.25 kN)

More details about the service loads can be found in Annex B and for the wind loads in Annex C.

We will define seven load cases in SCIA Engineer (**Load cases, Combinations > Load Cases**):

- LC1 – Self-weight (permanent load)
- LC2 – Service load, service condition (variable load)
- LC3 – Service load, out of service condition (variable load)
- LC4 – Maximum wind load X, parallel to façade (variable load)
- LC5 – Maximum wind load Y, perpendicular to façade (variable load)
- LC6 – Working wind load X, parallel to façade (variable load)
- LC7 – Working wind load Y, perpendicular to façade (variable load)

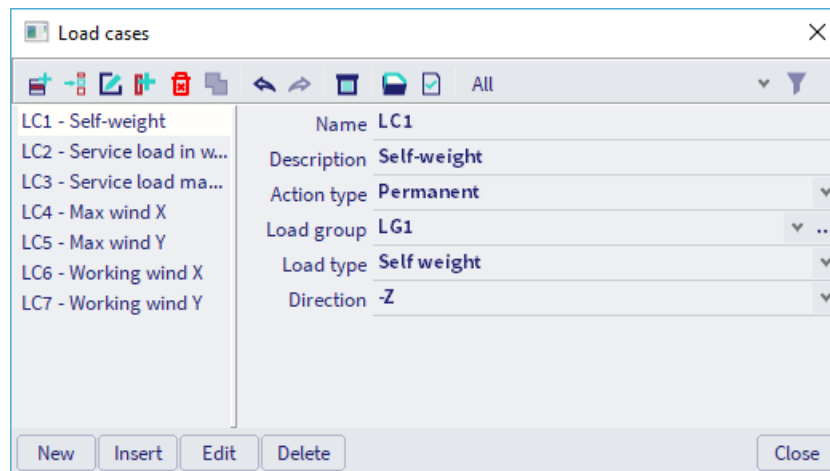

The accidental load is in many cases not considered in the analysis model.

2.1.1. LC1 – self-weight

This load case is automatically calculated by SCIA Engineer. It contains the self-weight of all elements that are present in the model (standards, ledgers, guardrails, diagonals, floorboards, toeboards).

2.1.2. LC2 – service load, service condition

This load case represents the service load that operates over the entire main floor. 'Main floor' means the most important/crucial floor of the scaffolding. If the load is put on this floor, it leads to the most critical values.

In this example, a class 3 scaffolding has been inserted, so a surface load of 200 kg/m², or **2.0 kN/m²** will be added (according to EN 12811-1 Table 3, q₁, see also Annex B of this manual):

Table 3 — Service loads on working areas (see also 6.2.2)

Load class	Uniformly distributed load q ₁ kN/m ²	Concentrated load on area 500 mm x 500 mm F ₁ kN	Concentrated load on area 200 mm x 200 mm F ₂ kN	Partial area load	
				q ₂ kN/m ²	Partial area factor a _p ¹
1	0,75 ²	1,50	1,00	---	---
2	1,50	1,50	1,00	---	---
3	2,00	1,50	1,00	---	---
4	3,00	3,00	1,00	5,00	0,4
5	4,50	3,00	1,00	7,50	0,4
6	6,00	3,00	1,00	10,00	0,5

This load is applied to the load panels and will be transferred to the floorboards.

Analogous above, also a service load is entered on the complete secondary floor if a scaffolding has more than one decked level. 'Secondary floor' refers to the working area at the first level above or below the main floor.

According to the code EN 12811-1, 50% of the service load must be put on the secondary floor, so we will add a load of **1.0 kN/m²** to the second top load panel.

You can add loads via **Input panel > Workstation Loads > Category Surface Loads > Surface load on 2D**.

2.1.3. LC3 – service load, out of service condition

This load case represents an accumulation of materials and equipment for the complete main working area (when the scaffolding is subject to the maximal wind load).

A percentage of the uniformly distributed service load (EN 12811-1, Table 3, q₁) acting on the working area of the most unfavourable decked level. The value of the percentage depends on the class of the scaffolding:

- Class 1: 0% (no service load on the working area)
- Classes 2 and 3: 25% (representing some stored materials on the working area)
- Classes 4, 5 and 6: 50% (representing some stored materials on the working area)

For our class 3 structure, we consider 25% of 2 kN/m², so we put a load of 0.5 kN/m² on the top floor.

Note: in some cases, it can be necessary to input a non-symmetric load on the construction. So, it can be important to input a load case, completely analogous to load case 3 or 4, but here the service load is only put on half of the main floor. By executing this load case, the structure is eccentrically loaded, so effects that counterbalance each other in a symmetrical load, are revealed here.

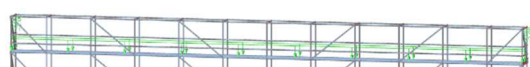

Fully loaded



Half loaded

2.1.4. LC4 – maximum wind load, parallel to façade

The wind peak velocity pressure for our example is 0.496 kN/m² (see Annex C for the calculation of this value).

The wind force can be calculated according to formula (VSB 5.8) of publication “Nederlandse Annex voor windbelasting op steigers” (Dutch Annex for wind load on scaffolds):

$$F_w = c_s c_d \cdot C_s \cdot C_f \cdot q_p(z) \cdot A_\varphi$$

- $c_s c_d$ structural factor (1 for height lower then 15 m, a reduction could be used for heights between 15 m and 50-60 m)
- C_s site coefficient, see figure VSB-6.2

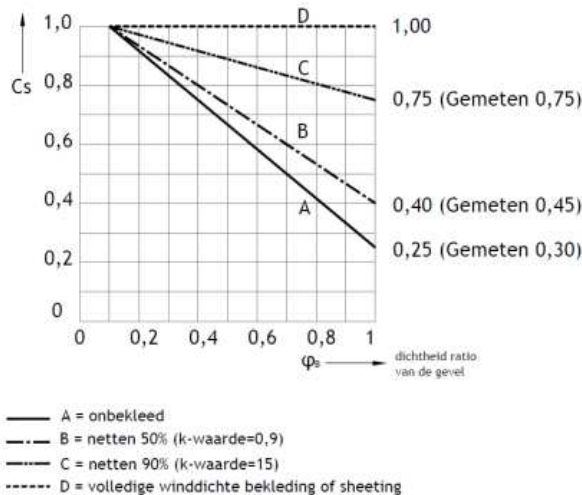

Figuur VSB-6.2 site coëfficiënt C_s

- C_f force coefficient
- $q_p(z)$ extreme wind pressure
- A_φ wind-catching area

So for an unclad scaffold, C_s can be taken as 0.25 for $\varphi_B = 1$:

$$F_w = 1.0 \cdot 0.25 \cdot 1.3 \cdot 0.496 \cdot A_\varphi = 0.161 \text{ kN/m}^2 \cdot A_\varphi$$

So a surface load of 0.161 kN/m² can be applied on the left load panel.

2.1.5. LC5 – maximum wind load, perpendicular to façade

In an analogous way, the maximal wind load is entered perpendicular to the façade on the structure.

A surface load of 0.161 kN/m² can be applied on the front load panel.

2.1.6. LC6 – working wind load, parallel to façade

The code EN 12811-1 §6.2.7.4.2 prescribes that if the scaffolding is into service, it only needs to be loaded with the so-called working wind load: *A uniformly distributed velocity pressure of 0.20 kN/m² shall be taken into account. To make allowance for equipment or materials being on the working area, a nominal reference area as defined in 6.2.7.4.1, but 400 mm high, shall be used in calculating working wind loads.*

The wind force can be calculated now with the wind load of 0.20 kN/m²:

$$F_w = 1.0 \cdot 0.25 \cdot 1.3 \cdot 0.200 \cdot A_\varphi = 0.065 \text{ kN/m}^2 \cdot A_\varphi$$

So a surface load of 0.065 kN/m² can be applied on the left load panel.

2.1.7. LC7 – working wind load perpendicular to façade

In an analogous way, the working wind load is entered perpendicular to the façade on the structure.

A surface load of 0.065 kN/m² can be applied on the front load panel.

2.2. Linear combinations

Following EN 12811-1, 6.2.9.2 the load cases have to be combined in two different ways: the service condition (service load in work and working wind loads) and the out of service condition (service load for maximal wind and maximum wind load).

Note: the service load shall be taken as zero if its consideration leads to more favourable results.

For the combinations in **Ultimate Limit State (ULS)**, a safety factor γ_F of **1.50** on the load cases is taken, conformable to the code EN 12811 §10.3.2. The safety factor γ_{M0} on the material is **1.10**.

Note: for Belgium and Netherlands a factor of 1.2 is used for the permanent load, according to VSB and VSBB (Dutch and Belgian association for scaffolding companies).

The ULS combinations are:

- CO1: 1.2*LC1 + 1.5*LC3 + 1.5*LC4 (max wind perpendicular + service load max wind)
- CO2: 1.2*LC1 + 1.5*LC3 + 1.5*LC5 (max wind parallel + service load max wind)
- CO3: 1.2*LC1 + 1.5*LC2 + 1.5*LC6 (working wind perpendicular + service load in service)
- CO4: 1.2*LC1 + 1.5*LC2 + 1.5*LC7 (working wind parallel + service load in service)

For the **Serviceability Limit State (SLS)** γ_F and γ_M shall be taken as **1.00**. The SLS combinations are:

- CO5: 1.0*LC1 + 1.0*LC3 + 1.0*LC4 (max wind perpendicular + service load max wind)
- CO6: 1.0*LC1 + 1.0*LC3 + 1.0*LC5 (max wind parallel + service load max wind)
- CO7: 1.0*LC1 + 1.0*LC2 + 1.0*LC6 (working wind perpendicular + service load in service)
- CO8: 1.0*LC1 + 1.0*LC2 + 1.0*LC7 (working wind parallel + service load in service)

The linear combinations are created in SCIA Engineer (**Menu bar > Libraries > Load cases, Combinations > Combinations > Combinations**):

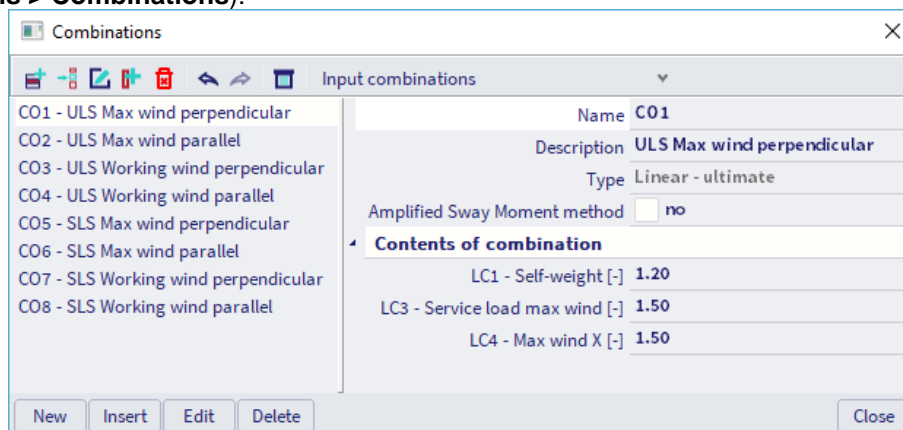

Note: depending on the used code other factors can be used. E.g. “NEN-EN 13814 Fair ground and amusement park machinery and structures” mentions a factor of 1.35 for the variable loads.

We can change the safety factor for steel in SCIA Engineer in the National Annex (which can be accessed via the status bar):

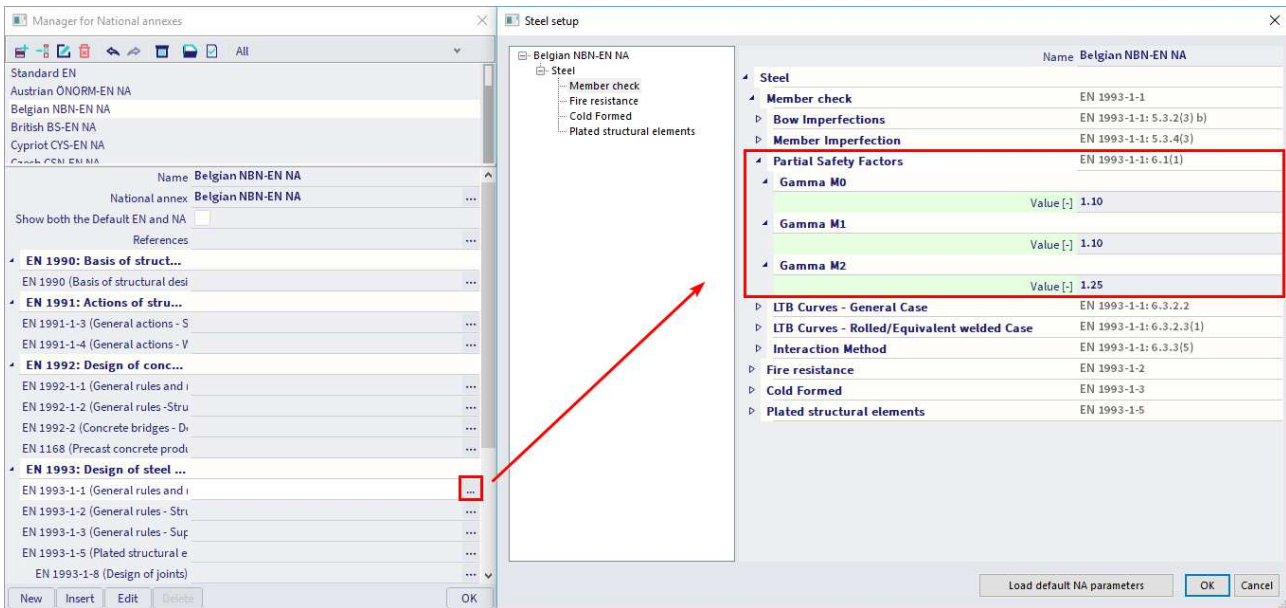

2.3. Stability combinations

To investigate the stability behaviour of our structure, we will perform a stability analysis. Therefore, we create four stability combinations from our linear combinations (**Menu bar > Libraries > Load cases, Combinations > Stability combinations**):

- S1: $1.2 \cdot LC1 + 1.5 \cdot LC3 + 1.5 \cdot LC4$
- S2: $1.2 \cdot LC1 + 1.5 \cdot LC3 + 1.5 \cdot LC5$
- S3: $1.2 \cdot LC1 + 1.5 \cdot LC2 + 1.5 \cdot LC6$
- S4: $1.2 \cdot LC1 + 1.5 \cdot LC2 + 1.5 \cdot LC7$

It is possible to import the linear combinations as stability combinations with the button **New from linear combinations** in the stability combinations dialog.

2.4. Nonlinear combinations

To include the nonlinearities in our model (gaps, nonlinear functions, ...) we will perform a nonlinear analysis. Therefore, we will create eight nonlinear combinations from our (linear) combinations (**Menu bar > Libraries > Load cases; Combinations > Nonlinear combinations**):

- NC1: $1.2 \cdot LC1 + 1.5 \cdot LC3 + 1.5 \cdot LC4$
- NC2: $1.2 \cdot LC1 + 1.5 \cdot LC3 + 1.5 \cdot LC5$
- NC3: $1.2 \cdot LC1 + 1.5 \cdot LC2 + 1.5 \cdot LC6$
- NC4: $1.2 \cdot LC1 + 1.5 \cdot LC2 + 1.5 \cdot LC7$
- NC5: $1.0 \cdot LC1 + 1.0 \cdot LC3 + 1.0 \cdot LC4$
- NC6: $1.0 \cdot LC1 + 1.0 \cdot LC3 + 1.0 \cdot LC5$
- NC7: $1.0 \cdot LC1 + 1.0 \cdot LC2 + 1.0 \cdot LC6$
- NC8: $1.0 \cdot LC1 + 1.0 \cdot LC2 + 1.0 \cdot LC7$

It is possible to import the linear combinations as nonlinear combinations with the button 'New from combination' in the nonlinear combinations window.

We will set bow and/or global imperfections for these nonlinear combinations in the following chapter.

Chapter 3: Analysis & results

In SCIA Engineer different analysis possibilities are available, but which kind of analysis should we perform for a scaffolding structure?

In code **EN 12810-2**, following table is mentioned:

Design stage	Path 1	Path 2
	Modular and frame systems	Frame systems only
1	Tests for configurations, connection devices and components	
2 / 3	Calculation for each system configuration of the standard set	
2	Determination of α_{cr}	
	Continuation of path 2 only if $\alpha_{cr} \geq 2$; if $\alpha_{cr} < 2$ change to path 1	
3	3a	Analysis of the structure to determine the distribution of forces and moments using Second order theory
	3b	Analysis of the individual components and connection to verify that the resistance is adequate
4	One test on a representative section of a system configuration	
	Type 1 For the verification of significant load displacement behaviour	Type 2 For the verification of α_{cr}

α_{cr} is the lowest elastic buckling load factor to be applied to the design loads

So, if we are working with modular systems (such as the Layher system), we should always perform a second order calculation.

This principle is also shown in the following flow chart of code **EN 12810-2**:

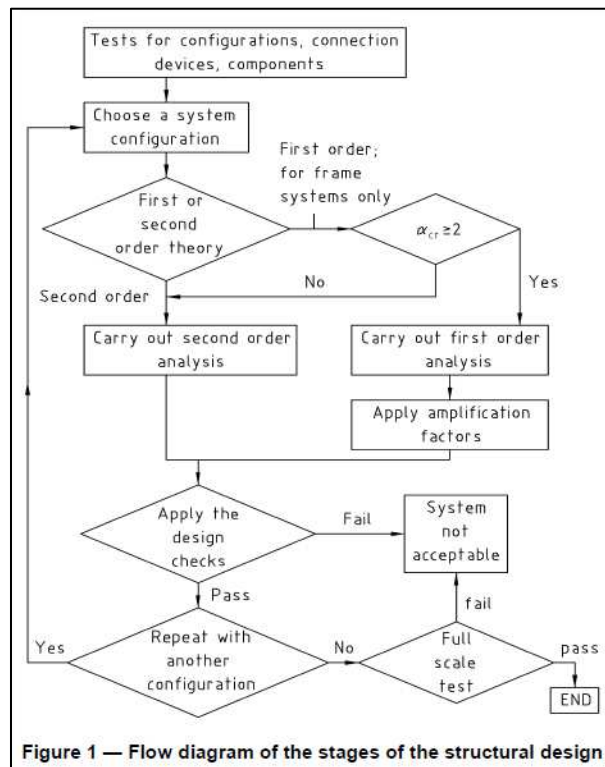

The general procedure for first order and second order analysis is shown in the following diagram (following EN 1993-1-1, chapter 5):

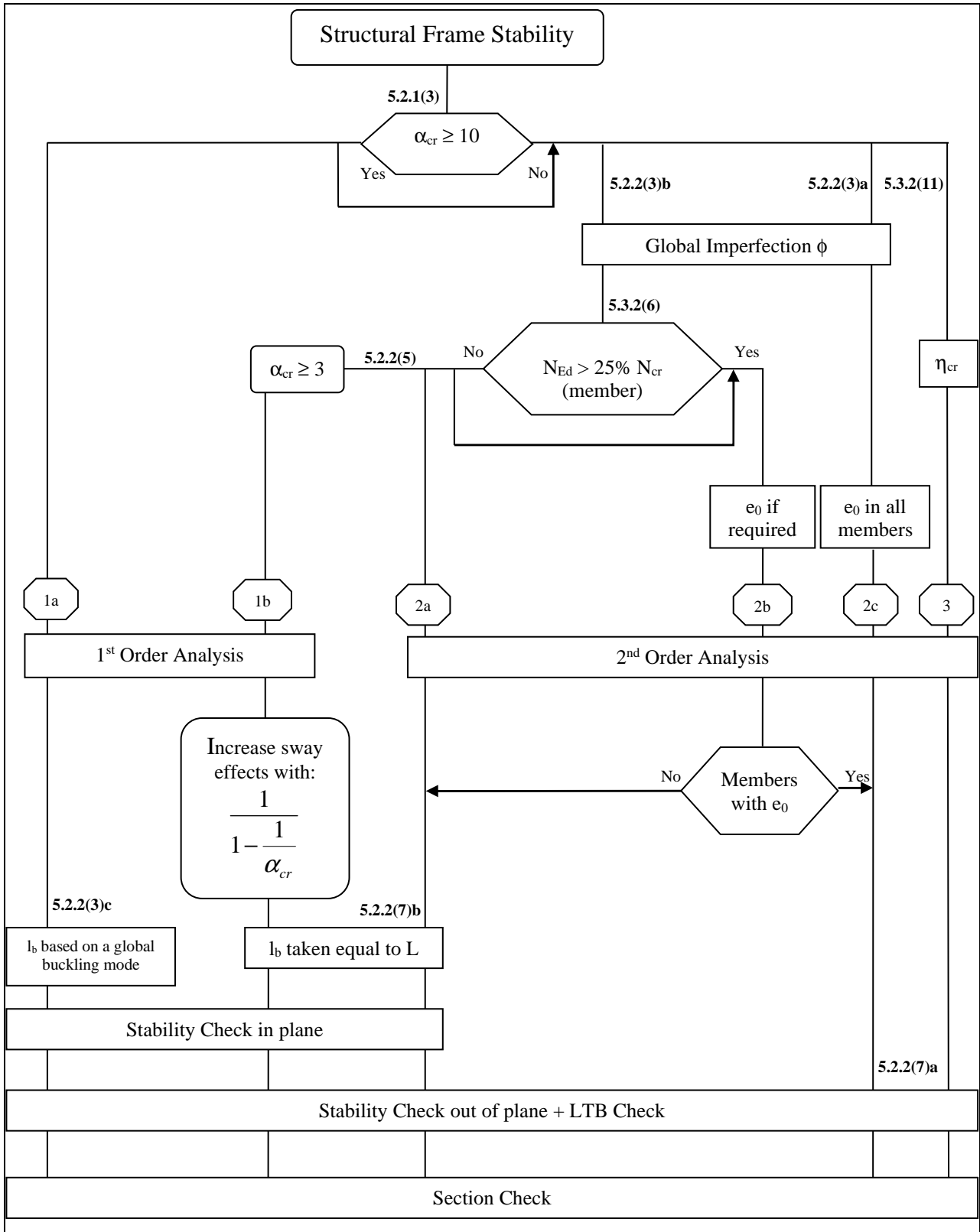

With:

- η_{cr} : elastic critical buckling mode
- L: member system length
- l_b : buckling length

Global analysis aims at determining the distribution of the internal forces and moments and the corresponding displacements in a structure subjected to a specified loading.

A distinction is between the methods, which make allowance for, and those, which neglect the effects of the actual, displaced configuration of the structure. They are referred to respectively as second order theory based and first order theory based methods.

The second order effects are made up of a local/member second order effects (referred to as the $P-\delta$ effect) and a global second order effect (referred to as the $P-\Delta$ effect).

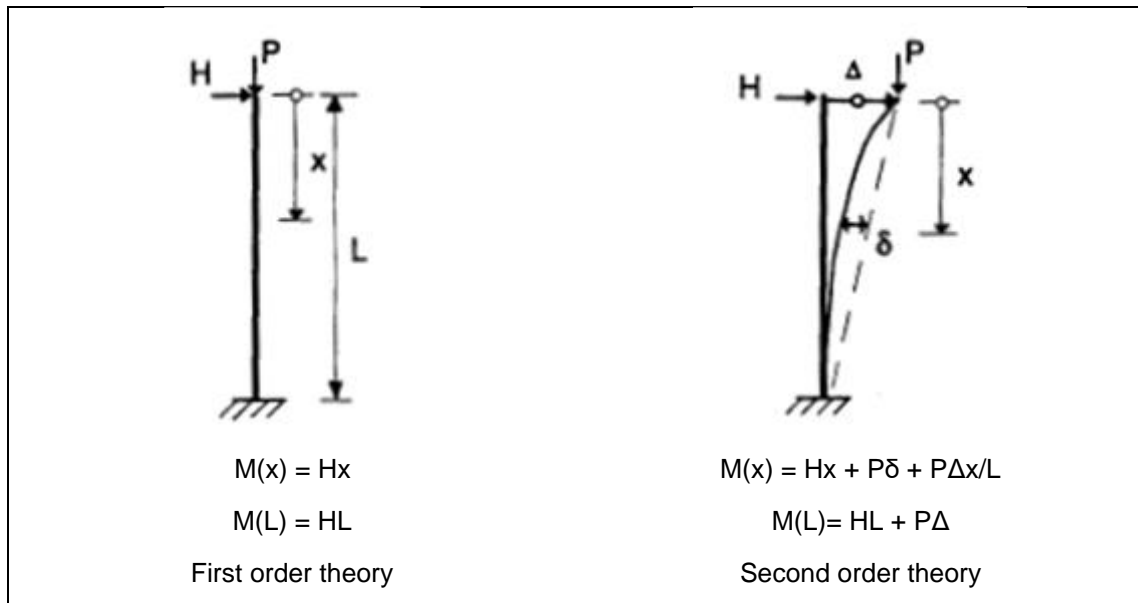

In the diagram of EN 1993 three paths are defined:

- Path 1: a first order calculation will be executed;
- Path 2: a second order calculation will be executed with global (and bow) imperfections;
- Path 3: a second order calculation will be executed with the buckling shape of the construction as imperfection.

The calculation will become more precise when choosing for a higher path. The lower paths will result in a faster calculation, because a first order calculation can be executed without iterations, but this first order theory may be used only when the displacement effects on the structural behaviour are negligible.

For our scaffolding structure, we should follow path 2 or 3 (since we should calculate with the second order effect according to EN 12810-2).

So, when we are designing scaffolding structures; following workflow can be used.

- First a linear analysis can be executed to have a look at the global behaviour of the structure.
- Then we can perform a stability analysis to investigate which stability modes should be considered if we want to follow path 3.
- Finally, we can create the nonlinear combinations with imperfections (global and local imperfections if we want to follow path 2 or the stability mode as a global imperfection if we want to follow path 3). We will execute the analysis with these nonlinear combinations and perform the checks with the results of them.

3.1. Linear analysis

First, we can start with a linear analysis for a global stability check of the whole structure:

- Is the model calculating properly (are there no instabilities)?
- Are the reactions logic?
- ...

Pay attention that it is mandatory to perform a second order analysis with imperfections! When you would perform the ULS checks with the linear combinations, a warning will be given in the output of the check.

3.1.1. Bill of material

The **bill of material** can also be found in the **results workstation** of the **process toolbar**. In this table the total length for each cross section is shown or the number of elements can be shown per member type and per length.

Bill of material

Selection: All
Type of sorting: Member (1D)

Summary

Material	Mass [kg]	Surface [m ²]	Volume [m ³]
Steel	13819.8	892.725	1.1050e+01
Timber	661.7	96.975	8.5566e-01
Total	14481.5	989.700	1.1906e+01

Steel (1D)

Member	Material	Count	Unit length [m]	Length [m]	Unit mass [kg/m]	Mass [kg]	Surface [m ²]	Volume [m ³]
Standard - RO48.3X3.2	S 235 (R eH ≥ 320 N/mm ²)	256	2.000	512.000	3.6	1820.7	77.824	2.3194e-01
Ledger - RO48.3X3.2	S 235 (R eH ≥ 320 N/mm ²)	141	1.090	153.690	3.6	546.5	23.361	6.9622e-02
Ledger - RO48.3X3.2	S 235 (R eH ≥ 320 N/mm ²)	44	2.070	91.080	3.6	323.9	13.844	4.1259e-02
Ledger - RO48.3X3.2	S 235 (R eH ≥ 320 N/mm ²)	208	2.570	534.560	3.6	1900.9	81.253	2.4216e-01
Guardrail - RO48.3X3.2	S 235 (R eH ≥ 320 N/mm ²)	40	1.090	43.600	3.6	155.0	6.627	1.9751e-02
Guardrail - RO48.3X3.2	S 235 (R eH ≥ 320 N/mm ²)	36	2.070	74.520	3.6	265.0	11.327	3.3758e-02
Guardrail - RO48.3X3.2	S 235 (R eH ≥ 320 N/mm ²)	176	2.570	452.320	3.6	1608.5	68.753	2.0490e-01
Bracing - RO48.3X2.3	S 235	20	2.278	45.555	2.6	118.7	6.924	1.5124e-02
Bracing - RO48.3X2.3	S 235	20	2.878	57.567	2.6	150.0	8.750	1.9112e-02
Bracing - RO48.3X2.3	S 235	40	3.257	130.261	2.6	339.5	19.800	4.3247e-02
Floorboard - Full rectangular (40; 320)	FB 0.32	54	2.070	111.780	8.2	916.6	80.482	1.4308e+00
Floorboard - Full rectangular (40; 320)	FB 0.32	264	2.570	678.480	8.2	5563.3	488.506	8.6845e+00
Beam lattice girder - RO48.3X3.2	S 235 (R eH ≥ 320 N/mm ²)	10	0.500	5.000	3.6	17.8	0.760	2.2650e-03
Beam lattice girder - RO48.3X3.2	S 235 (R eH ≥ 320 N/mm ²)	4	5.140	20.560	3.6	73.1	3.125	9.3137e-03
Diagonal lattice girder - RRO30X20X2K	S 235	24	0.619	14.919	1.4	20.3	1.389	2.5810e-03
Total		1337		2925.891		13819.8	892.725	1.1050e+01

Timber(1D)

Member	Material	Count	Unit length [m]	Length [m]	Unit mass [kg/m]	Mass [kg]	Surface [m ²]	Volume [m ³]
TB 0.15 - RECT (20; 150)	TB 0.15	20	1.090	21.800	2.3	50.6	7.412	6.5400e-02
TB 0.15 - RECT (20; 150)	TB 0.15	18	2.070	37.260	2.3	86.4	12.668	1.1178e-01
TB 0.15 - RECT (20; 150)	TB 0.15	88	2.570	226.160	2.3	524.7	76.894	6.7848e-01
Total		126		285.220		661.7	96.975	8.5566e-01

3.2. Stability analysis

Now we will perform a stability calculation, which calculates the global buckling mode/shape (eigenmode) of a structure under the given loading. We will have a look at the stability modes, to decide which modes we want to impose as imperfection (according to path 3 of the EN 1993 diagram).

The stability calculation is available with module sens.01 (for linear stability analysis) or module sens.03 (for nonlinear stability analysis).

The stability combinations are already created in the previous chapter.

To obtain precise results, the number of 1D elements is refined through **Menu bar > Tools > Calculation & Mesh > Mesh settings** (a minimum number of 4 elements is required):

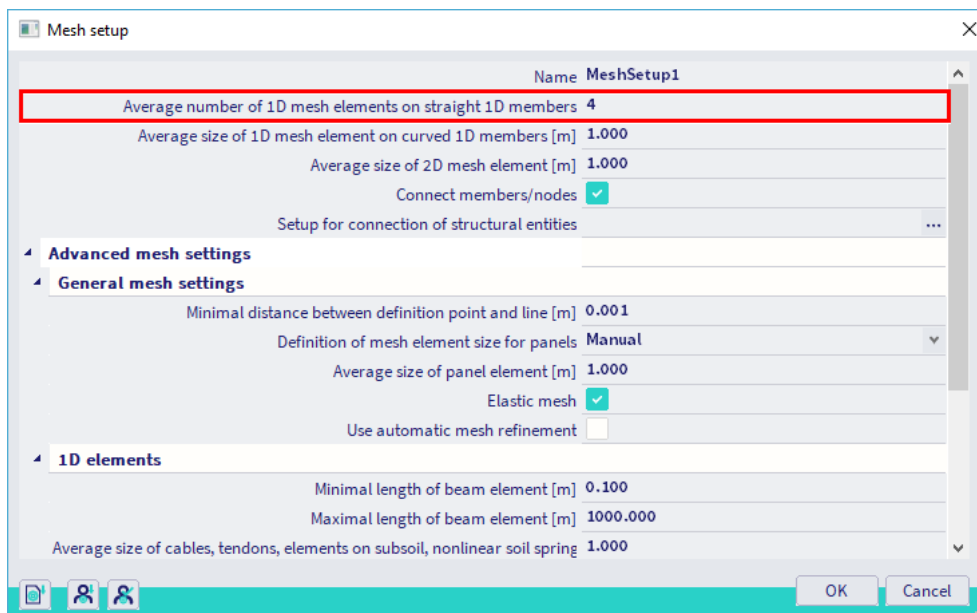

Under **Menu bar > Tools > Calculation & Mesh > Solver settings** the **Type of eigen value solver** and **Number of buckling modes** can be specified:

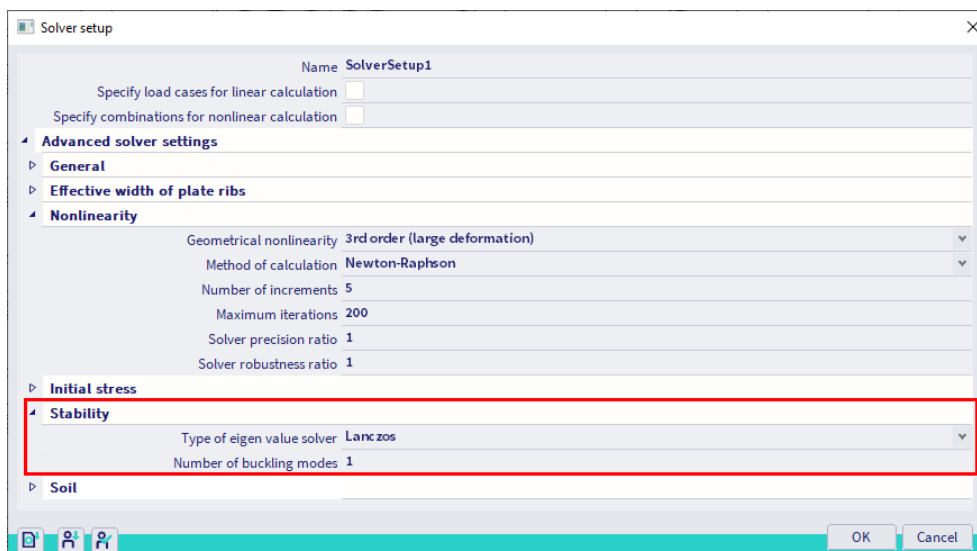

You can start with 1 or 2 buckling modes and evaluate if a global mode is found. If not, you can increase the number of buckling modes or you can change the element that is too weak.

Since we have nonlinearities in our model, we must execute the **nonlinear stability analysis** to take these nonlinearities into account. We need to activate the functionality **Geometrical nonlinearity** and choose as geometrical nonlinearity for **3rd order (large deformation)** in the solver settings (see also Annex D – Nonlinear analysis).

After the calculation we can have a look at the alpha critical (α_{cr}) values under **Menu bar > Results > Critical load coefficients**:

Critical load coefficients

N	f
-	□
Stability combination : S1	
1	3.80
Stability combination : S2	
1	3.80
Stability combination : S3	
1	2.20
Stability combination : S4	
1	2.40

For a visualisation of the buckling modes, we can go to **Menu bar > Results > 3D deformations** and select the appropriate stability combination. For stability combination S4 we clearly see a buckling shape at the location of the opening in our structure:

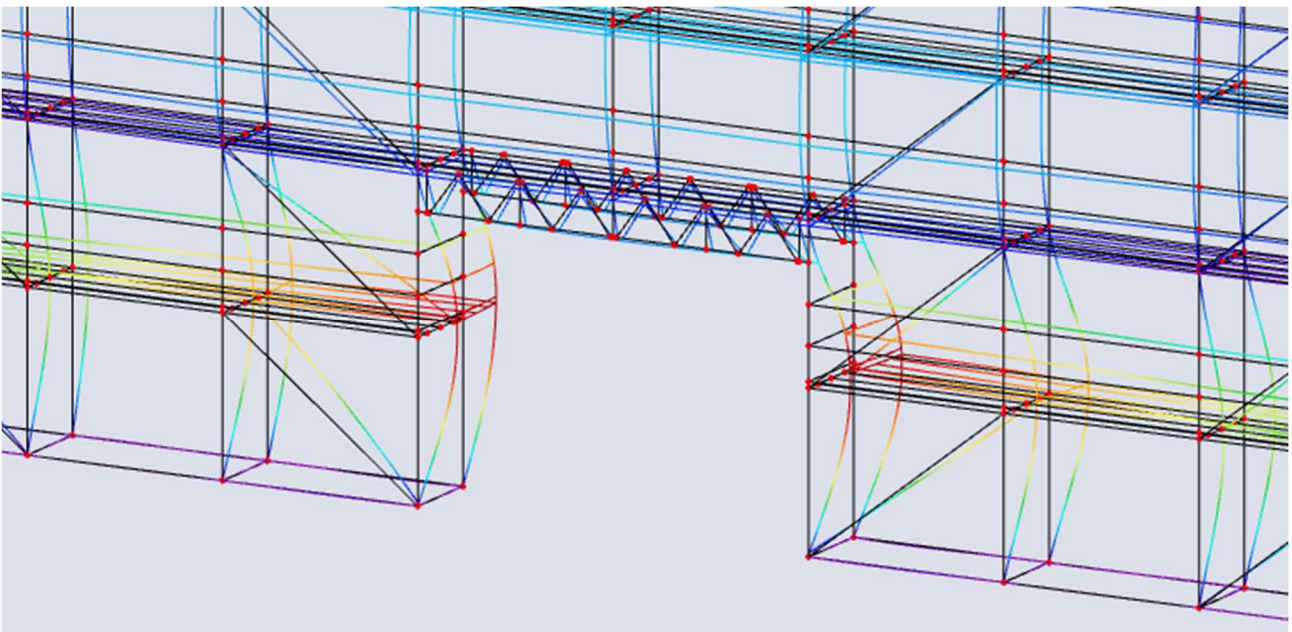

This means we must consider this buckling shape in our nonlinear combinations and analysis.

3.3. Nonlinear analysis

3.3.1. Global frame imperfection ϕ

Inclination functions

The global frame imperfection can be inputted for the whole structure by an imperfection value ϕ . This value can be calculated with the following formula (EN 1993-1-1 art. 5.3.2(3)a):

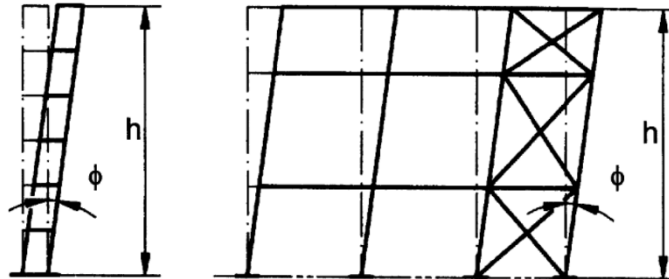

- $\phi = \frac{1}{200} \cdot \alpha_h \cdot \alpha_m$
- $\alpha_h = \frac{2}{\sqrt{h}}$, but $\frac{2}{3} \leq \alpha_h \leq 1.0$
- $\alpha_m = \sqrt{0.5 \cdot \left(1 + \frac{1}{m}\right)}$
- h: height of the structure in meters
- m: number of columns in a row including only those columns which carry a vertical load N_{Ed} not less than 50% of the average value of the vertical load per column in the plane considered

These inclination functions are entered through **Menu bar > Libraries > Structure and analysis > Initial deformations**:

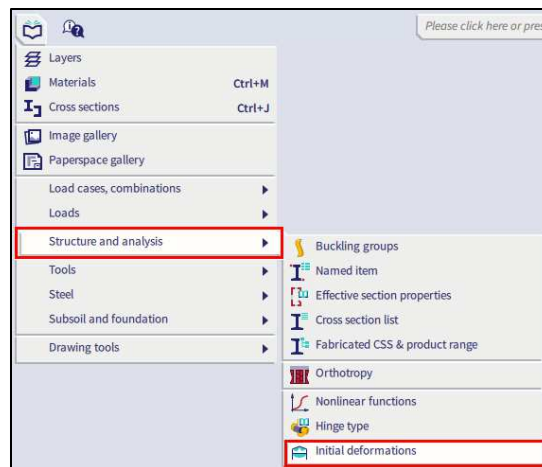

We will create two functions: one for the X direction and one for the Y direction:

- the type is chosen as **EN 1993-1-1 art. 5.3.2(3)**, with a basic imperfection of **1/200**;
- the height of the construction is **20 m**;
- there are 12 columns in the X direction, therefore the number of columns in this direction has been inputted as **12**;
- There are 2 columns in the Y direction, therefore the number of columns in this direction has been inputted as **2**;

The inclination function for the X direction (DefX) is displayed below:

Name	DefX
Type	EN 1993-1-1 art. 5.3.2(3)
Basic imperfection value : 1 / [-]	200.00
Height of structure : [m]	20.000
Number of columns per plane :	12
	ϕ : 0.00245300
α_h : [-]	0.67
α_m : [-]	0.74

If you have a structure with an irregular shape, you'll need to enter all nonlinear combinations four times: once with the inclination according to the positive X direction, once according to the positive Y direction, once according to the negative X direction and once for the negative Y direction.

In our model we have a scaffolding with anchoring every 4 m. Therefore, we will apply a factor on the inclination functions DefX and DefY. We consider that the deformation will be zero at 4 m, 8 m, 12 m, 16 m and 20 m. This results in following function:

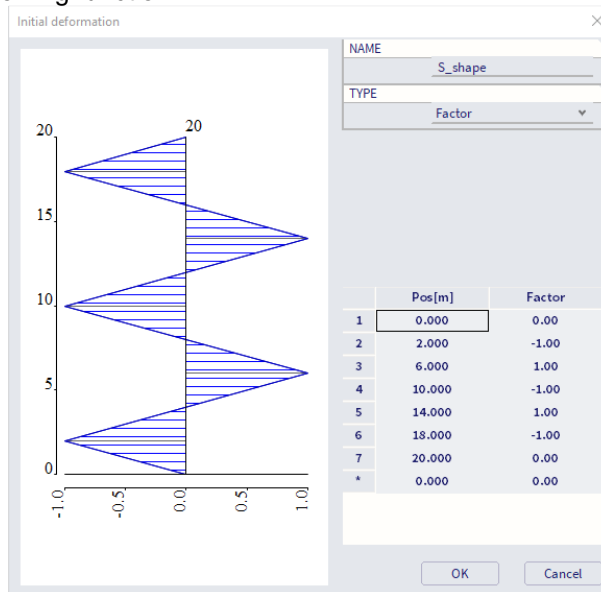

We have already created nonlinear combinations NC_CO1-NC_CO8, which we will give an inclination in **X direction** with factor **S_shape**.

We can copy those eight combinations (so NC_CO9-NC_CO16 are created) and we change the inclination to **Y direction** with factor **S_shape**.

Now we have 16 nonlinear combinations:

The screenshot shows the "Nonlinear combinations" dialog box. On the left is a list of combinations from NC_CO1 to NC_CO16. NC_CO1-NC_CO8 are grouped under "DefX" and NC_CO9-NC_CO16 under "DefY". The right pane shows the settings for NC_CO1. The "Global imperfection" is set to "Inclination functions". Under "dx inclination functions", the Z-axis is set to "DefX" and the Factor is "S_shape".

Stability shape as imperfection

As an alternative to global and local imperfections, we can use a buckling shape as a unique imperfection (according to path 3 of the EN 1993 diagram). Since we have an important buckling shape around the opening in our structure, we need to check this situation as well. Therefore, we will copy our first eight nonlinear combinations NC_CO1-NC_CO8 and apply buckling shape S4 as global imperfection on them.

Since the buckling shape is dimensionless, Eurocode gives a formula to calculate the amplitude η_{init} of the imperfection:

$$\eta_{init} = e_0 \cdot \frac{N_{cr}}{E \cdot I_y \cdot \eta_{cr,max}''} \cdot \eta_{cr}$$

With:

- $e_0 = \alpha \cdot (\bar{\lambda} - 0.2) \cdot \frac{M_{Rk}}{N_{Rk}} \cdot \frac{1 - \chi \cdot (\bar{\lambda})^2}{1 - \chi \cdot (\bar{\lambda})^2}$ for $\bar{\lambda} > 0.2$
- $\bar{\lambda} = \sqrt{N_{Rk}/N_{cr}}$
- α : imperfection factor for the relevant buckling curve
- χ : reduction factor for the relevant buckling curve, depending on the relevant cross-section
- N_{Rk} : characteristic resistance to normal force of the critical cross-section, i.e. $N_{pl,Rk}$
- N_{cr} : elastic critical buckling load
- M_{Rk} : characteristic moment resistance of the critical cross-section, i.e. $M_{el,Rk}$ or $M_{pl,Rk}$ as relevant
- η_{cr} : shape of the elastic critical buckling mode
- $\eta_{cr,max}''$: maximal second derivative of the elastic critical buckling mode

Often η_{init} is taken as $L/200$. So, for our project we will set a maximum deformation of 20 mm, which corresponds with $L/200$ for a height of 4 m (since our buckling shape occurred over a height of 4 m):

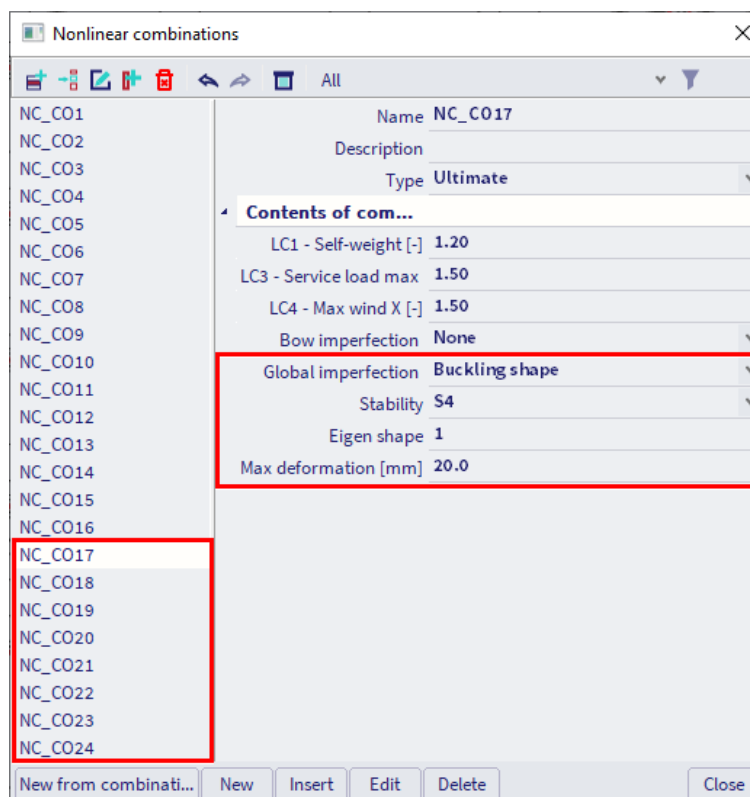

Annex D described an example where the value for η_{init} is calculated exactly.

3.3.2. Initial bow imperfection e_0

The initial bow imperfection e_0 is given by:

Buckling curve acc. to Table 6.1	elastic analysis	plastic analysis
	e_0 / L	e_0 / L
a_0	1 / 350	1 / 300
a	1 / 300	1 / 250
b	1 / 250	1 / 200
c	1 / 200	1 / 150
d	1 / 150	1 / 100



The buckling curve used for calculation of the imperfection is the curve inputted in the cross-section library. For standard sections, the curve according to the code is automatically used, for non-standard cross sections (as general cross sections) you need to input the buckling curve manually.

SCIA Engineer can calculate the bow imperfection according to the code automatically for all needed members. But in a scaffolding structure all profiles have the same buckling curve and thus the same bow imperfection. This bow imperfection is inputted as **simple curvature**: the same curvature for all members:

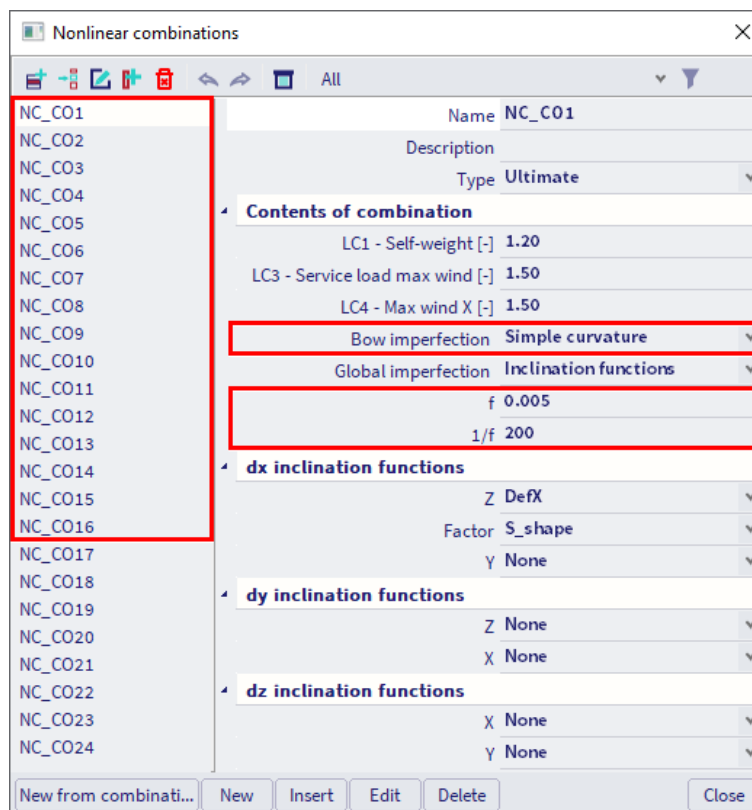

Note: for nonlinear combinations NC_CO17-NC_CO24 it is not necessary to activate the bow imperfection, since the local imperfection is included already in the buckling shape.

Note: in the Netherlands, a guideline for scaffolding structures mentions as value for the global imperfection $\tan \varphi = 0.00157$ and as value for the local imperfection $L/200$.

3.3.3. Second order calculation

First, do not forget to turn on the functionality **Geometrical nonlinearity** in the project settings dialogue to consider the second order analysis!

The method that we will use for our second order calculation is the so-called **Newton-Raphson** method (Th.III.O) for the solution of nonlinear equations.

This method is a more general applicable method which is very solid for most types of problems. It can be used for very large deformations and rotations, however the limitation of small strains is still applicable.

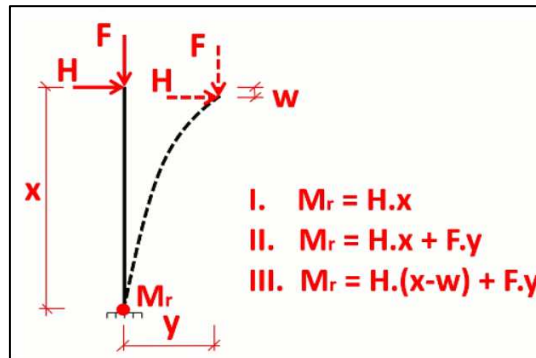

Mathematically, the method is based on a step-by-step augmentation of the load. This incremental method is illustrated on the following diagram:

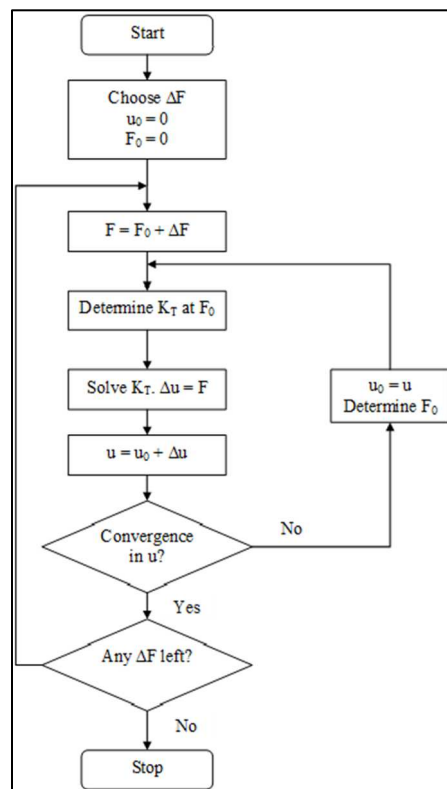

In this figure, the tangential stiffness K_T is used. The symbol \mathbf{u} depicts the displacements and \mathbf{F} is the force matrix.

The original Newton-Raphson method changes the tangential stiffness in each iteration. There are also adapted procedures which keep the stiffness constant in certain zones during for example one increment. SCIA Engineer uses the original method.

As a limitation, the rotation achieved in one increment should not exceed 5°.

The accuracy of the method can be increased through refinement of the finite element mesh and by increasing the number of increments. By default, when the Newton-Raphson method is used, the **Number of increments** is set to **5** (in the solver setup) and you should set the number of **1D elements** to at least **4** in the mesh setup (we choose already for 5 as average number of tiles of 1D element when we performed the stability calculation).

In the mesh settings we also advise to deactivate the option **Generation of nodes in connections of beam elements** (by default this option is ticked off):



When this option is activated, beams will be connected by the nodes they are going through. But when 4 nodes are inputted on the beams, it could happen that a node has been inputted in the middle of a diagonal and another diagonal is crossing this one in the program and now they are connected. To avoid unwanted connections, we advise to uncheck this option.

The criterion for convergence is defined as follows:

$$\frac{\sum(u_{x,i}^2 + u_{y,i}^2 + u_{z,i}^2) - \sum(u_{x,i-1}^2 + u_{y,i-1}^2 + u_{z,i-1}^2)}{\sum(u_{x,i}^2 + u_{y,i}^2 + u_{z,i}^2)} \leq 0,005/(\text{precision ratio})$$

With:

- $u_{x,i}$: displacement in direction x for iteration i
- $u_{y,i}$: displacement in direction y for iteration i
- $u_{z,i}$: displacement in direction z for iteration i

This convergence precision (solver precision ratio) can be adapted in the solver settings (Menu bar > Tools > **Calculation & Mesh > Solver Settings**), together with the choice for the Newton-Raphson method, the amount of increments and the maximal amount of iterations. The default value for the maximal amount of iterations is 20, but it can be necessary to increase this value (for example to 50, 100, ...) if there is no convergence after 20 iterations.

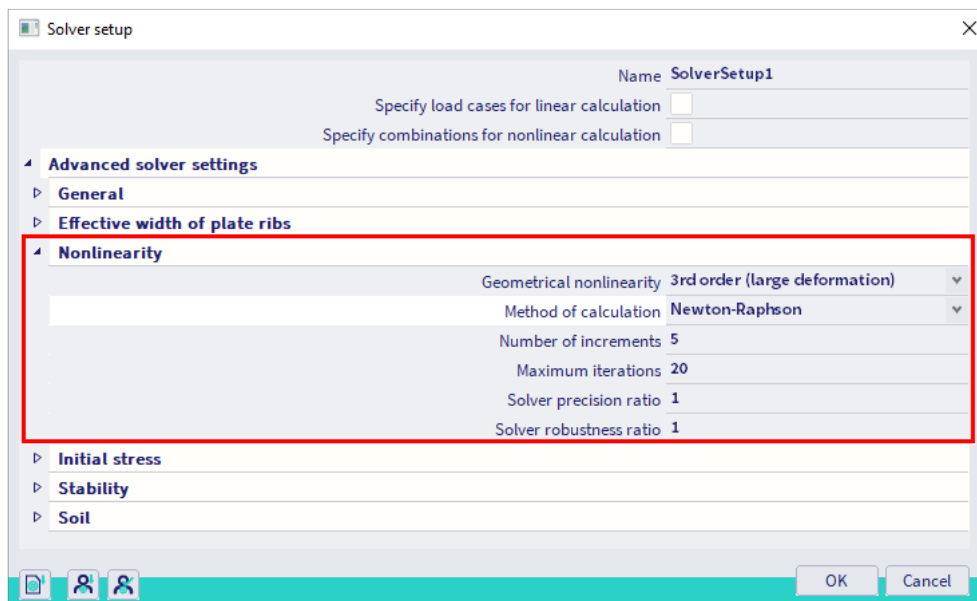

In some cases, a high number of increments may even solve problems that tend to a singular solution which is typical for the analysis of post-critical states. However, in most cases, such a state is characterized by extreme deformations, which is not interesting for design purposes.

As specified, the Newton-Raphson method can be applied in nearly all cases. It may, however fail in the vicinity of inflexion points of the loading diagram. To avoid this, a specific method has been implemented in SCIA Engineer: the **Modified Newton-Raphson** method.

Also, when the Newton-Raphson method is failing, there is the possibility of the method of Picard. This method follows the same principles as the default method but will automatically refine the number of increments when a critical point is reached. This method is used for the nonlinear stability calculation.

Chapter 4: Checks

4.1. Member check

4.1.1. SLS check

The deformation check in SLS (Serviceability Limit State) is a part of Eurocode 3. According to the code EN 12811-1 the allowable deformation for the total deflection is $L/100$. You can set the limit value via **Menu bar > Design > Steel members > Settings > SLS deflection check** (or **Menu bar > Design > Aluminium > Settings > SLS deflection check**):

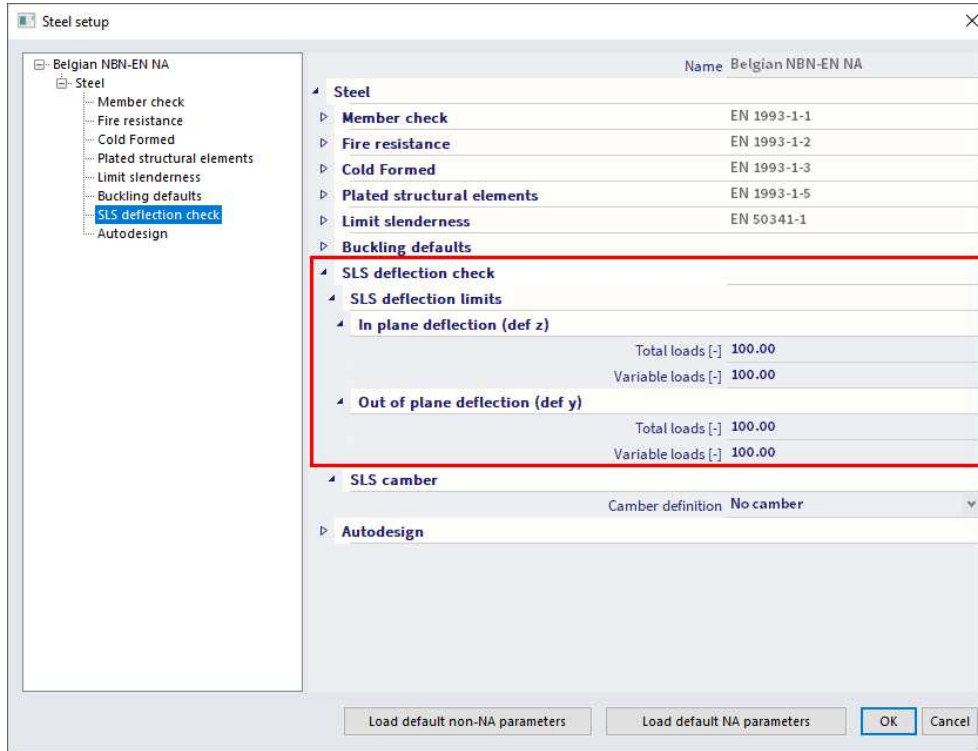

Choose for **Menu bar > Design > Steel members > SLS check** (or **Aluminium > SLS check** in case you have modelled aluminium elements, this functionality is available in the 64bit version since SCIA Engineer 22.0) and ask the results for the nonlinear class **NC_SLS**:

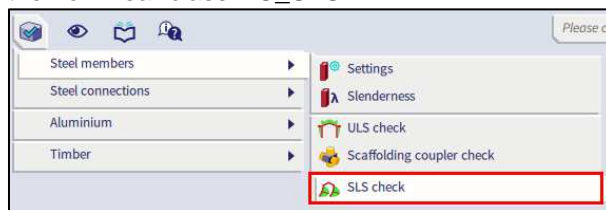

The maximum unity check of 0.29 is found for beam B859:

EC-EN 1993 Steel Check SLS
 Values: Check Overall
 Nonlinear calculation
 Class: NC_SLS
 Coordinate system: Principal
 Extreme 1D: Global
 Selection: All

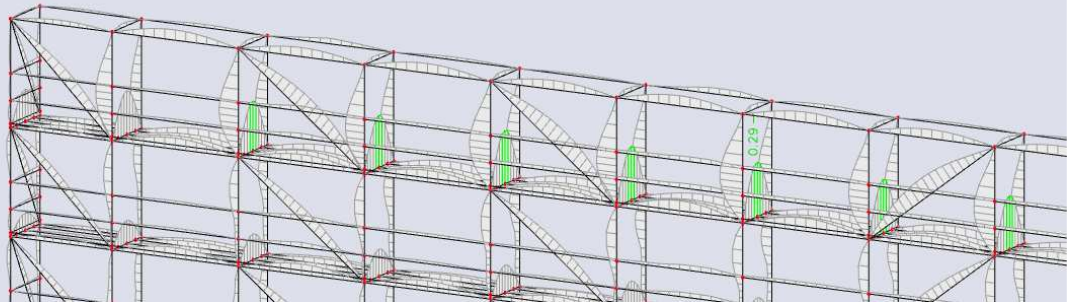

EC-EN 1993 Steel Check SLS

Nonlinear calculation
 Class: NC_SLS
 Coordinate system: Principal
 Extreme 1D: Global
 Selection: All

Overall Unity Check

Name	dx [m]	Case	$u_{y,max}$	$u_{y,var}$	Lim. $u_{y,max}$	Lim. $u_{y,var}$	Check	Check	Camber dx u_z [mm] Camber [mm]	Check Overall [-]
			$u_{z,max}$	$u_{z,var}$	Lim. $u_{z,max}$	Lim. $u_{z,var}$	$u_{y,max}$ [-] Check	$u_{y,var}$ [-] Check		
B859	0.545-	NC_CO16	0.0 -3.2	0.0 -2.8	3.2 10.9	3.2 10.9	0.00 0.29	0.00 0.26	- -	0.29

4.1.2. ULS check

The scaffolding check is executed according to equation 9 of EN 12811-1-1 article 10.3.3.2. However, the EN 12811-1 only gives an interaction equation in case of a low shear force. Since the EN 12811-1 is based entirely on DIN 4420-1 Teil 1 the interaction formulas according to Tabelle 7 of DIN 4420-1 Teil 1 are applied in case of a large shear force. The interaction equations are summarised as follows

Conditions	Interaction for tubular member
$\left(\frac{N}{N_{pld}} \leq \frac{1}{10}\right) \text{ and } \left(\frac{V}{V_{pld}} \leq \frac{1}{3}\right)$	$\frac{M}{M_{pld}}$
$\left(\frac{1}{10} < \frac{N}{N_{pld}} \leq 1\right) \text{ and } \left(\frac{V}{V_{pld}} \leq \frac{1}{3}\right)$	$\frac{M}{M_{pld} \cdot \cos\left(\frac{\pi \cdot N}{2 \cdot N_{pld}}\right)}$
$\left(\frac{N}{N_{pld}} \leq \frac{1}{10}\right) \text{ and } \frac{1}{3} < \frac{V}{V_{pld}} \leq 0.9$	$\frac{M}{M_{pld} \cdot \sqrt{1 - \left(\frac{V}{V_{pld}}\right)^2}}$
$\left(\frac{1}{10} < \frac{N}{N_{pld}} \leq 1\right) \text{ and } \frac{1}{3} < \frac{V}{V_{pld}} \leq 0.9$	$\frac{M}{M_{pld} \cdot \left[\sqrt{1 - \left(\frac{V}{V_{pld}}\right)^2} \cos\left(\frac{\pi \cdot N}{2 \cdot N_{pld} \cdot \sqrt{1 - \left(\frac{V}{V_{pld}}\right)^2}}\right) \right]}$
$\frac{V}{V_{pld}} > 0.9$	$\frac{V}{0.9 \cdot V_{pld}}$
$\frac{N}{N_{pld}} > 1$	$\frac{N}{N_{pld}}$

With:

- M : $\sqrt{M_y^2 + M_z^2}$
- V : $\sqrt{V_y^2 + V_z^2}$
- α : $\frac{W_{pl}}{W_{el}} \leq 1.25$
- N_{pld} : $\frac{A \cdot f_y}{\gamma_M}$
- V_{pld} : $\frac{2 \cdot A \cdot f_y}{\pi \cdot \sqrt{3} \cdot \gamma_M}$
- M_{pld} : $\frac{\alpha \cdot W_{el} \cdot f_y}{\gamma_M}$
- γ_M : safety factor, taken as γ_{M0} of EN 1993-1-1 for steel couplers or γ_{M1} of EN 1999-1-1 for aluminium couplers

Only section checks are executed since the stability effects are considered in the second order calculation with imperfections and a lateral torsional buckling check is not relevant for tubular profiles. In case these conditions are not set the default EN 1993-1-1 check will be executed instead.

Choose for **Menu bar > Design > Steel members > ULS check** (or **Menu bar > Design > Aluminium > ULS check** in case you have modelled aluminium elements) and ask the results for the nonlinear class NC_ULS:

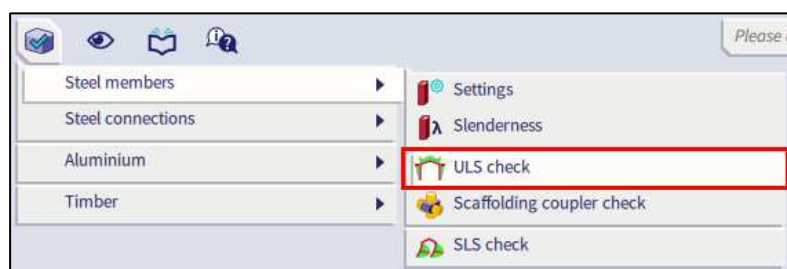

In the properties window you can choose for **Brief**, **Summary** or **Detailed** as output type:

- Brief output: the results are shown in one line;
- Summary output: the results of all the individual unity checks are shown;
- Detailed output: the results of all the individual unity checks are shown. Since SCIA Engineer 19.0 also each individual formula can be shown. You can choose to print only the tables, only the formulas or both.

The maximum unity check of 0.60 is found for beam B859:

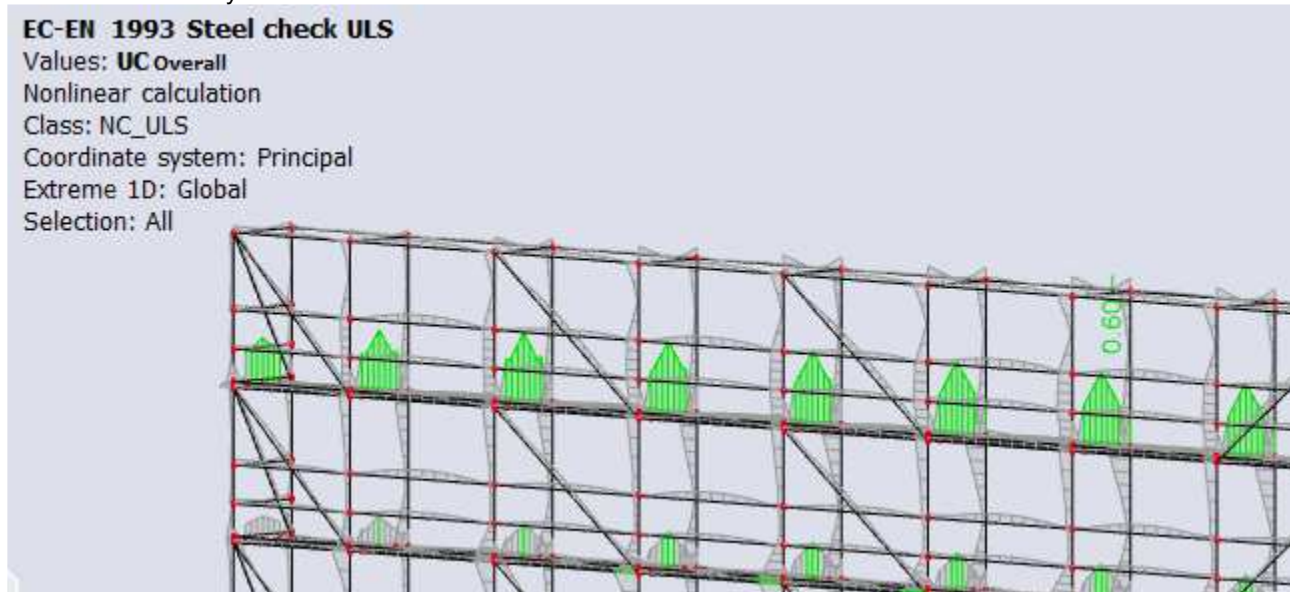

EC-EN 1993 Steel check ULS

Nonlinear calculation
 Class: NC_ULS
 Coordinate system: Principal
 Extreme 1D: Global
 Selection: All

EN 1993-1-1 Code Check

EN 12811-1 Scaffolding Check

National annex: Belgian NBN-EN NA

Member B859	0.545 / 1.090 m	R048.3X3.2	Rolled	S 235 (R eH ≥ 320 N/mm ²)	NC_ULS	0.60 -
-------------	-----------------	------------	--------	--	--------	--------

Combination key	
NC_ULS / NC_CO4	

Partial safety factors		
Resistance of cross-sections	γ_{M0}	1.10
Resistance to instability	γ_{M1}	1.10
Resistance of net sections	γ_{M2}	1.25

Material		
Yield strength	f_y	320.0 MPa
Ultimate strength	f_u	360.0 MPa

....SECTION CHECK:....

The critical check is on position 0.545 m

Internal forces		Calculated	Unit
Normal force	N_{Ed}	0.04	kN
Shear force	$V_{y,Ed}$	-0.01	kN
Shear force	$V_{z,Ed}$	-1.41	kN
Torsion	T_{Ed}	0.00	kNm
Bending moment	$M_{y,Ed}$	1.04	kNm
Bending moment	$M_{z,Ed}$	0.01	kNm

Scaffolding check for tubular members

According to EN 12811-1 & DIN 4420 Teil 1 article 5.4.7.4 and table 7

Normal force resistance	$N_{pl,d}$	131.78	kN
Shear resistance	$V_{pl,d}$	48.44	kN
Bending resistance	$M_{pl,d}$	1.75	kNm
Unity check N		0.00	-
Unity check V		0.03	-
Unity check M		0.60	-
Unity check Interaction		0.60	-
Unity check Max		0.60	-

$$\alpha_{pl} = \min \left(\frac{W_{pl,y}}{W_{el,y}}, 1.25 \right) = \min \left(\frac{6.5088 \cdot 10^{-6} [m^3]}{4.8000 \cdot 10^{-6} [m^3]}, 1.25 \right) = \min (1.36, 1.25) = 1.25$$

$$N_{pl,d} = \frac{A \times f_y}{\gamma_{M0}} = \frac{4.5300 \cdot 10^{-4} [m^2] \times 320.0 [MPa]}{1.10} = 131.78 [kN]$$

$$V_{pl,d} = \frac{A \times \frac{f_y}{\sqrt{3}}}{\gamma_{M0}} \times \frac{2}{\pi} = \frac{4.5300 \cdot 10^{-4} [m^2] \times \frac{320.0 [MPa]}{\sqrt{3}}}{1.10} \times \frac{2}{\pi} = 48.44 [kN]$$

$$M_{pl,d} = \alpha_{pl} \times W_{el,y} \times \frac{f_y}{\gamma_{M0}} = 1.25 \times 4.8000 \cdot 10^{-6} [m^3] \times \frac{320.0 [MPa]}{1.10} = 1.75 [kNm]$$

$$\text{Unity check N} = \frac{|N_{Ed}|}{N_{pl,d}} = \frac{0.04 [kN]}{131.78 [kN]} = \mathbf{0.00} \leq \mathbf{1.00}$$

$$\text{Unity check V} = \frac{V_{resultant}}{V_{pl,d} \times 0.9} = \frac{1.41 [kN]}{48.44 [kN] \times 0.9} = \mathbf{0.03} \leq \mathbf{1.00}$$

$$\text{Unity check M} = \frac{M_{resultant}}{M_{pl,d}} = \frac{1.04 [kNm]}{1.75 [kNm]} = \mathbf{0.60} \leq \mathbf{1.00}$$

Unity check Interaction = Unity check M = **0.60** ≤ **1.00**

Unity check = max (Unity check Interaction, Unity check N, Unity check V, Unity check M) = max (0.60, 0.00, 0.03, 0.60) = **0.60** ≤ **1.00**

The member satisfies the section check.

SCIA Engineer will show you directly the scaffolding check, when choosing for the Eurocode check for circular hollow sections, because we have activated the **Scaffolding** functionality in the beginning of the project. If you do not want to see the scaffolding check, but the general Eurocode check (EN 1993-1-1), you can uncheck this option in the **steel settings**:

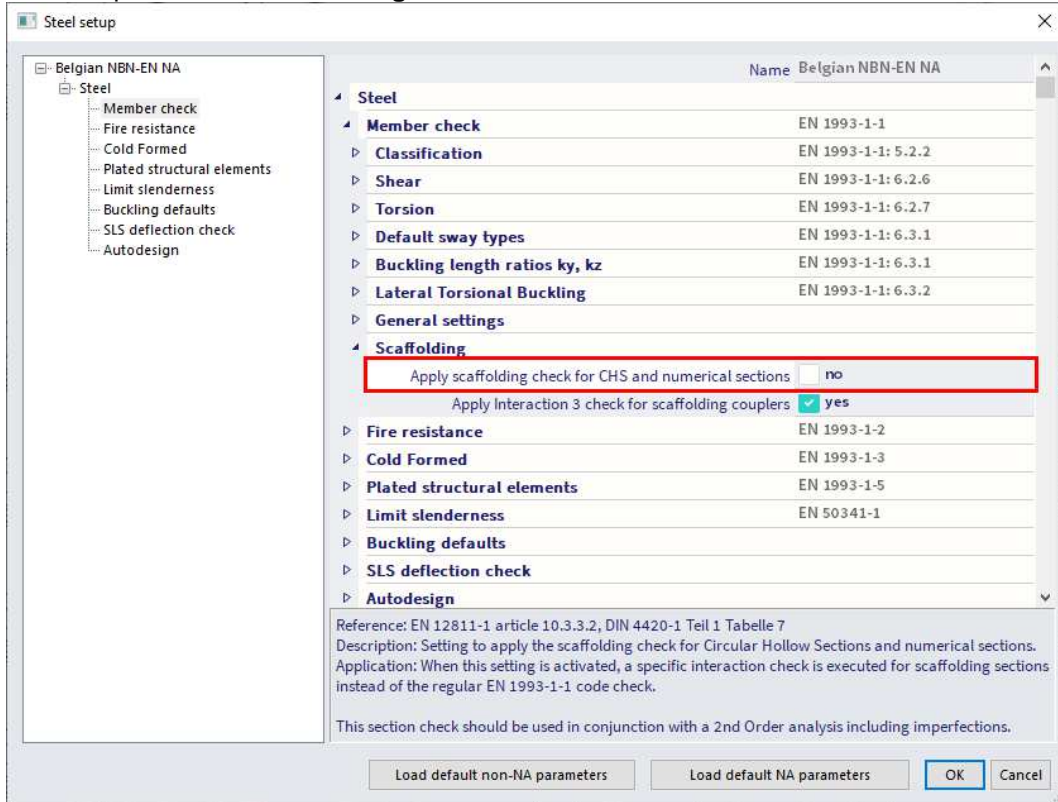

You can find the same option in the **Aluminium Settings** if you are working with aluminium elements and you want to follow EN 1999-1-1 instead of the specific scaffolding check.

4.2. Coupler check

When checking the allowable stresses, it is recommended to view the results per profile type (standards, bracings, ...). The maximal stresses can now be compared to the allowable values of the supplier. Also the base jacks are checked with this value.

For the anchorage forces, the reaction force can be tested to the allowable force of a perpendicular coupler. On the other hand, the anchorage can also be checked manually on the combined effect of tension and shear.

For the couplers, this check can be performed by SCIA Engineer itself, with the option **Menu bar > Design > Steel members > Scaffolding coupler check** (or **Menu bar > Design > Aluminium > Scaffolding coupler check** for aluminium couplers).

This check performs a unity check for the couplers for which a maximal allowable force is given in the coupler library:



4.2.1. General couplers

Following table provides an overview of the performed component checks for each type:

	F _x	F _y	F _z	M _x	M _y	M _z	Interaction
Right angle	✓	✓	✓	✓	✓	✓	✓
Friction sleeve	✓	-	-	-	✓	-	✓
Swivel	✓	-	-	-	-	-	-
Base jack	-	-	-	-	✓	✓	-
Parallel	-	-	✓	-	-	-	-
General	✓	✓	✓	✓	✓	✓	-

For a right angle coupler the interaction formula is:

$$\frac{N + V_z}{2 \cdot \frac{F_{s,k}}{\gamma_M}} + \frac{V_y}{\frac{F_{p,k}}{\gamma_M}} + \frac{M_y}{2.4 \cdot \left(\frac{M_{B,k}}{\gamma_M}\right)} = \frac{|N_{Ed}| + |V_{z,Ed}|}{\frac{N_{x,k} + V_{z,k}}{\gamma_M}} + \frac{|V_{y,Ed}|}{\frac{V_{y,k}}{\gamma_M}} + \frac{|M_{y,Ed}|}{2.4 \cdot \left(\frac{M_{y,k}}{\gamma_M}\right)} \leq 1$$

For a friction sleeve coupler the formula is:

$$\frac{N}{2 \cdot \frac{F_{s,k}}{\gamma_M}} + \frac{M_y}{\frac{M_{B,k}}{\gamma_M}} = \frac{|N_{Ed}|}{2 \cdot \frac{N_{x,k}}{\gamma_M}} + \frac{|M_{y,Ed}|}{\frac{M_{y,k}}{\gamma_M}} \leq 1$$

With:

- F_{s,k}: characteristic slipping force, taken as N_{x,k} and V_{z,k} of the coupler properties: 2F_{s,k}=N_{x,k}+V_{z,k}
- F_{p,k}: characteristic pull-apart force, taken as V_{y,k} of the coupler properties
- M_B: characteristic bending moment, taken as M_{y,k} of the coupler properties
- N: normal force
- V_y: shear force in y direction
- V_z: shear force in z direction
- M_y: bending moment about the y axis
- γ_M: safety factor, taken as γ_{M0} of EN 1993-1-1 for steel couplers or γ_{M1} of EN 1999-1-1 for aluminium couplers
- N_{x,k}, V_{y,k}, V_{z,k}, M_{y,k}: coupler resistances given by EN 12811-1 Table C1

Loads on a coupler are defined by following figures (left below is a right angle coupler and right below is a friction type sleeve coupler), see also Annex A:

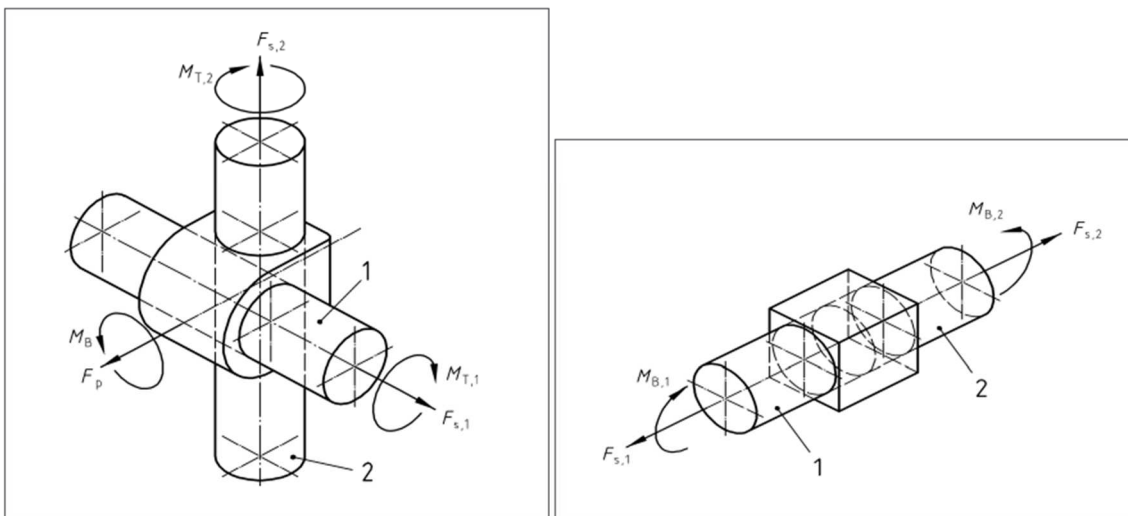

4.2.2. Manufacturer couplers

In addition to the list of general couplers, following table provides an overview of the performed component checks for each type of manufacturer coupler:

	F_x	F_y	F_z	M_x	M_y	M_z	Interaction 1	Interaction 2	Interaction 3
Cuplok	✓	-	✓	✓	✓	-	✓	✓	✓
Layher K2000+	✓	✓	✓	✓	✓	✓	✓	✓	✓
Layher Variante II	✓	✓	✓	-	✓	✓	✓	✓	✓
Layher LW	✓	✓	✓	✓	✓	✓	✓	✓	✓
Catari US	✓	✓	✓	-	✓	-	-	-	-

Notes:

- The Catari US coupler type and the interaction 3 check are available since SCIA 20.
- Since SCIA21.1 it is possible to turn off the interaction 3 check via the steel settings.

Cuplock

The Cuplock coupler which connects a ledger and a standard is described in Zulassung Nr. Z-8.22-208:2017. The interaction equations are:

Interaction 1:

$$\frac{N}{\frac{N_{x,k}}{\gamma_M}} + \frac{M_y}{\frac{M_{y,k}}{\gamma_M}} + \frac{M_x}{\frac{M_{x,k}}{\gamma_M}} = \frac{|N_{Ed}|}{\frac{N_{x,k}}{\gamma_M}} + \frac{|M_{y,Ed}|}{\frac{M_{y,k}}{\gamma_M}} + \frac{|M_{x,Ed}|}{\frac{M_{x,k}}{\gamma_M}} \leq 1$$

With:

- N : slipping force, taken as normal force in the ledger
- M_y : bending moment about the y axis
- M_x : torsional moment around the x axis
- γ_M : safety factor, taken as γ_{M0} of EN 1993-1-1 for steel couplers or γ_{M1} of EN 1999-1-1 for aluminium couplers
- $N_{x,k}$, $M_{y,k}$, $M_{x,k}$: coupler resistances given by Z-8.22-208:2017 Table 4

Interaction 2:

$$\frac{M_y}{\frac{M_{y,k}}{\gamma_M}} + \frac{(N + N_v \cdot \sin(\alpha))}{\frac{N_{x,k}}{\gamma_M}} + \frac{M_x}{\frac{M_{x,k}}{\gamma_M}} = \frac{|M_{y,Ed}|}{\frac{M_{y,k}}{\gamma_M}} + \frac{|N_{Ed} + \sum (N_{v,Ed} \cdot \sin(\alpha))|}{\frac{N_{x,k}}{\gamma_M}} + \frac{|M_{x,Ed}|}{\frac{M_{x,k}}{\gamma_M}} \leq 1$$

With:

- N : slipping force, taken as normal force in the ledger
- M_y : bending moment about the y axis
- M_x : torsional moment around the x axis
- N_v : normal force in a connecting vertical diagonal
- γ_M : safety factor, taken as γ_{M0} of EN 1993-1-1 for steel couplers or γ_{M1} of EN 1999-1-1 for aluminium couplers
- α : angle between connecting vertical diagonal and standard
- $N_{x,k}$, $M_{y,k}$, $M_{x,k}$: coupler resistances given by Z-8.22-208:2017 Table 4

Interaction 3:

$$I_S + 0.7 \cdot I_A = \frac{a}{b} + 0.7 \cdot I_A = \frac{\sqrt{m_{act}^2 + n_{act}^2}}{\sqrt{m^2 + n^2}} + 0.7 \cdot I_A \leq 1$$

With:

- I_A : M_y utilization of connected coupler
- I_S : in-plane utilization of column (the definition of lengths a and b are given by article 3.3.2.2 build 1)
- a: initial length
- b: projected length
- m_{act} : actual utilization of in-plane bending moment in column section = $\frac{|M_{st,Ed}|}{M_{st,Rd}}$
- $M_{st,Ed}$: design bending moment in column section adjacent to the coupler
- $M_{st,Rd}$: bending moment resistance of the column cross-section = $\frac{\alpha_{pl} \cdot w_{el} \cdot f_{yk}}{\gamma_M}$ and $\alpha_{pl} = \frac{w_{pl}}{w_{el}} \leq 1.25$
- n_{act} : actual utilization of normal force in column section = $\frac{|N_{st,Ed}|}{N_{st,Rd}}$
- $N_{st,Ed}$: design normal force in column section adjacent to the coupler
- $N_{st,Rd}$: normal force resistance of column cross-section = $\frac{A_{st} \cdot f_{yk}}{\gamma_M}$
- m: value of bending moment utilization when combined UC is equal to 1 (the smallest positive root of the cubic function)
- n: corresponding value of normal force utilization calculated from current curve function = $\left(\frac{n_{act}}{m_{act}}\right) \cdot m$
- A_{st} : cross-section area of column cross-section
- $w_{el/pl}$: elastic / plastic section modulus of column cross-section
- v_{act} : actual utilization of vertical in-plane shear in column section = $\frac{|V_{st,Ed}|}{V_{st,Rd}}$
- $V_{st,Ed}$: design shear force in column section adjacent to the coupler
- $V_{st,Rd}$: shear force resistance of column cross-section = $\frac{A_{v,st} \cdot f_{yk}}{\sqrt{3} \cdot \gamma_M}$
- γ_M : safety factor, taken as γ_{M0} of EN 1993-1-1 for steel couplers or γ_{M1} of EN 1999-1-1 for aluminium couplers

Column internal forces are selected considering the possible rotation of the column. If the angle between the connected beam LCS and column LCS is smaller than 45 deg, then:

- $M_{st,Ed} = M_{y,st,Ed}$, else $M_{z,st,Ed}$
- $V_{st,Ed} = V_{y,st,Ed}$, else $V_{z,st,Ed}$

Also, in certain geometries there can be two sections to choose from. In this case the selection is based on Von Mises stress calculation. The section which will result in larger stress will be used for the further calculation of I_S . The stress will be calculated as indicated below:

$$\sigma = \sqrt{\sigma_{tot,Ed}^2 + 3 \cdot \tau_{Ed}^2} = \sqrt{(\sigma_N + \sigma_M)^2 + 3 \cdot \tau_{Ed}^2} = \sqrt{\left(\frac{|N_{st,Ed}|}{A_{st}} + \frac{|M_{st,Ed}|}{W_{el,st}}\right)^2 + 3 \cdot \left(\frac{|V_{st,Ed}|}{A_{v,st}}\right)^2}$$

The bending moment utilization of column m, may be calculated by solving a derived cubic function, using coefficients C_1 and C_2 depending on the shear force utilization of column section v_{act} :

$$C_2 \cdot m^3 + 4 \cdot C_1 \cdot C_2 \cdot m^2 + 4 \cdot m - 4 \cdot C_1 = 0$$

With:

- C_1 : for $v_{act} \leq \frac{1}{3}$: $C_1 = 1$
for $\frac{1}{3} \leq v_{act} \leq 0.9$: $C_1 = \sqrt{1 - v_{act}^2}$
- C_2 : for $v_{act} \leq \frac{1}{3}$: $C_2 = \frac{n_{act}}{m_{act}}$
for $\frac{1}{3} \leq v_{act} \leq 0.9$: $C_2 = \frac{n_{act}}{m_{act}} \cdot \sqrt{1 - v_{act}^2}$

Special cases are:

- $m_{act} \leq 0.0001 \rightarrow I_s = n_{act}$
- $n_{act} = 0 \rightarrow I_s = m_{act}$
- $m_{act} \leq 0.0001$ and if $n_{act} = 0 \rightarrow I_s = 0$

For the case when $0.9 < V_{act}$ an error will be displayed and UC_Interaction 3 will be set to 999.

To recognize a member as a column, the type of the member has to be either '**column**', '**gable column**' or '**secondary column**' and the cross-section has to be Formcode 3 (CHS). In case two columns are found, both need to be within one buckling system. If the above is not fulfilled or if there are more column members found, the column geometry is not recognized and the unity check is set to 999.

Layher

The Layher coupler which connects a ledger and a standard is described in Zulassung Nr. Z-8.22-64:2018 for Variante II and Variante K2000+ and in Zulassung Nr. Z-8.22-939:2019 for Variante LW.

Interaction 1, Variante II:

$$\frac{N^{(+)}}{N_{Rd}} + \frac{M_y}{M_{y,Rd}} + \frac{\max(V_z - 1.4 ; 0)}{M_y} + \frac{V_y}{25.0} = \frac{N_{Ed}^+}{\gamma_M} + \frac{|M_{y,Ed}|}{\gamma_M} + \frac{\max(|V_{z,Ed}| - V_{z,Ed,min} ; 0)}{\gamma_M} + \frac{|M_{z,Ed}|}{\gamma_M} + \frac{|V_{y,Ed}|}{V_{y,Rd}} \leq 1$$

Interaction 1, Variante K2000+:

$$\frac{N^{(+)}}{N_{Rd}} + \frac{M_y}{M_{y,Rd}} + \frac{\max(V_z - 2.1 ; 0)}{M_y} + \frac{V_y}{27.1} + \frac{M_T}{M_{T,Rd}} \leq 1$$

$$\frac{N_{Ed}^+}{\gamma_M} + \frac{|M_{y,Ed}|}{\gamma_M} + \frac{\max(|V_{z,Ed}| - V_{z,Ed,min} ; 0)}{\gamma_M} + \frac{|M_{z,Ed}|}{\gamma_M} + \frac{|V_{y,Ed}|}{V_{y,Rd}} + \frac{|M_{x,Ed}|}{\gamma_M} \leq 1$$

Interaction 1, Variante LW:

$$\frac{N^{(+)}}{N_{Rd}} + \frac{|M_y|}{M_{y,Rd}} + \frac{\max(|V_z| - 2.5 ; 0)}{V_{z,Rd}} + \frac{|M_z|}{|M_{z,Rd}|} + \frac{|V_y|}{|V_{y,Rd}|} + \frac{M_T}{M_{T,Rd}} \leq 1$$

$$\frac{N_{Ed}^+}{\gamma_M} + \frac{|M_{y,Ed}|}{\gamma_M} + \frac{\max(|V_{z,Ed}| - V_{z,Ed,min} ; 0)}{\gamma_M} + \frac{|M_{z,Ed}|}{\gamma_M} + \frac{|V_{y,Ed}|}{V_{y,Rd}} + \frac{|M_{x,Ed}|}{\gamma_M} \leq 1$$

Note: an additional check for welds is not supported.

With:

- N: slipping force, taken as normal force in the ledger
- (+): this index indicates a tensile force (≥ 0)
- V_y : shear force in y direction
- V_z : shear force in z direction
- M_y : bending moment about the y axis
- M_x : torsional moment around the x axis
- M_z : torsional moment around the z axis
- γ_M : safety factor, taken as γ_{M0} of EN 1993-1-1 for steel couplers or γ_{M1} of EN 1999-1-1 for aluminium couplers
- α : angle between connecting vertical diagonal and standard
- $N_{x,k}$, $M_{y,k}$, $M_{z,k}$, $M_{x,k}$, $V_{y,k}$, $V_{z,k}$: coupler resistances given by Z-8.22-64:2018 Table 5 for Variante II and Variante K2000+ en Z-8.22-939:2019 Table 5 for Variante LW
- $V_{z,Ed,min}$: 1.4 kN for Variante II, 2.1 kN for Variante K2000+ and 2.5 kN for Variante LW

Interaction 2:

$$(n^A + n^B)^2 + (v^A + v^B)^2 \leq 1$$

Ledger A / Vertical diagonal B	
n^A	$\frac{N^{A(+)} + M_y^A / e}{\xi N_{R,d}}$
n^B	$\frac{0,707 \sin \alpha N_V^{(+)} + \left(\frac{e_D}{e}\right) \cdot \cos \alpha N_V }{\xi N_{R,d}}$
v^A	$\frac{V_z^A}{V_{z,R,d}}$
v^B	$\frac{\cos \alpha N_V}{V_{z,R,d}}$

Ledger:

$$nA = \frac{N_{Ed}^+ + \frac{|M_{y,Ed}|}{e}}{\xi \cdot \frac{N_{x,k}}{\gamma_M}}$$

$$nB = \frac{0.707 \cdot \sum(\sin(\alpha) \cdot N_{v,Ed}^+) + \frac{e_D}{e} \cdot \sum(\cos(\alpha) \cdot |N_{v,Ed}|)}{\xi \cdot \frac{N_{x,k}}{\gamma_M}}$$

Vertical diagonal:

$$vA = \frac{V_{z,Ed}}{\frac{V_{z,k}}{\gamma_M}}$$

$$vB = \frac{\sum(\cos(\alpha) \cdot N_{v,Ed})}{\frac{V_{z,k}}{\gamma_M}}$$

With:

- N: slipping force, taken as normal force in the ledger
- (+): this index indicates a tensile force (≥ 0)
- N_v : normal force in a connecting vertical diagonal
- M_y : bending moment about the y axis
- V_z : shear force in z direction
- γ_M : safety factor, taken as γ_{M0} of EN 1993-1-1 for steel couplers or γ_{M1} of EN 1999-1-1 for aluminium couplers
- α : angle between connecting vertical diagonal and standard
- $N_{x,k}$, $V_{z,k}$: coupler resistances given by Z-8.22-64:2018 Table 5 for Variante II and Variante K2000+ en Z-8.22-939:2019 Table 5 for Variante LW
- e: 2.75 cm for Variante II, 3.30 cm for Variante K2000+ and 3.30 kN for Variante LW
- e_D : 5.7 cm
- ξ : 1.26 cm for Variante II, 1.85 cm for Variante K2000+ and 1.85 kN for Variante LW

Interaction 3, Variante II:

$$I_S + 0.148 \cdot I_A = \frac{\sigma_N}{f_{yd}} + 0.148 \cdot I_A = \frac{\frac{|N_{st,Ed}|}{A_{st}} + \frac{|M_{st,Ed}|}{W_{el,st}}}{f_{yd}} + 0.148 \cdot I_A \leq 1$$

With:

- I_A : My utilization of connected coupler
- I_S : in-plane utilization of column
- $N_{st,Ed}$: design normal force in column section adjacent to the coupler
- $M_{st,Ed}$: design bending moment in column section adjacent to the coupler
- A_{st} : cross-section area of column cross-section
- $W_{el,st}$: elastic section modulus of column cross-section

Interaction 3, Variante K2000+ (given by Z-8.22-64 Table 6):

$$I_S + 0.316 \cdot I_A \leq 1$$

The calculation routine is similar as the one described for Cuplok coupler.

Interaction 3, Variante LW (given by Z-8.22-939):

$$I_S + 0.170 \cdot I_A \leq 1$$

The calculation routine is similar as the one described for Cuplok coupler.

Catari US

The resistances and stiffness function of Catari Universal System (US) coupler are given by AENOR Product Certificate A34/000035. The reference only provides normal force resistance for tension.

Choose for **Menu bar > Design > Steel members > Scaffolding coupler check** (or **Menu bar > Design > Aluminium Scaffolding coupler check** in case you have modelled aluminium elements) and ask the results for the nonlinear class NC_ULS:

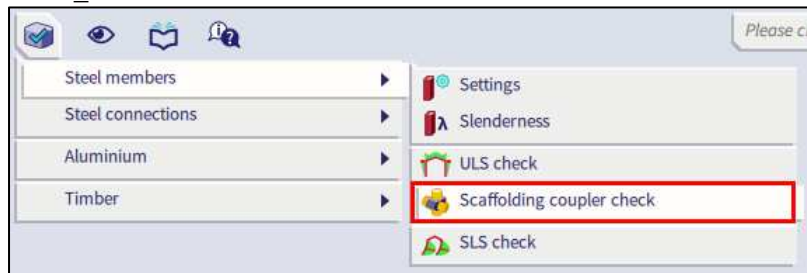

The maximum unity check of 0.59 is found in coupler H1300 (on beam B5919):

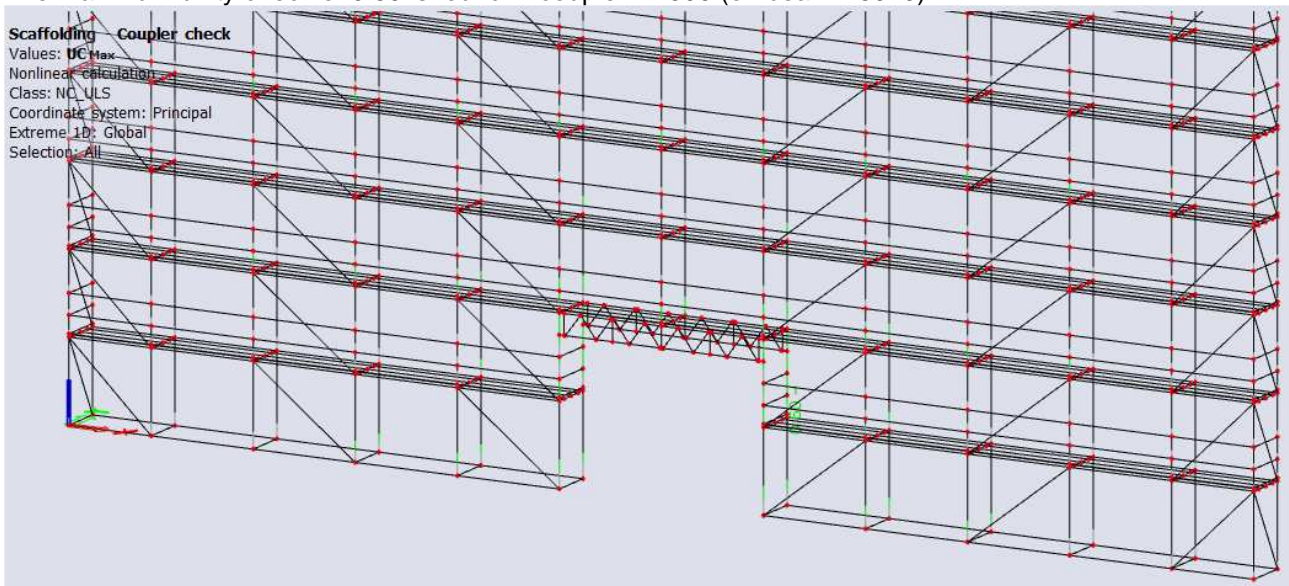

Scaffolding - Coupler check
 Values: UC_{Max}
 Nonlinear calculation
 Class: NC_ULS
 Coordinate system: Principal
 Extreme 1D: Global
 Selection: All

Scaffolding - Coupler check

Nonlinear calculation
 Class: NC_ULS
 Coordinate system: Principal
 Extreme 1D: Global
 Selection: All

Scaffolding - Coupler Check

Name	dx [m]	Case	UC _{Max} [-]	UC _{Fx} [-]	UC _{Fy} [-]	UC _{Fz} [-]	UC _{Mtx} [-]	UC _{Mty} [-]	UC _{Mtz} [-]	UC _{Interaction1} [-]	UC _{Interaction2} [-]	UC _{Interaction3} [-]
S5919	0.000	NC_CO20	0.59	0.46	0.02	0.11	0.00	0.09	0.00	0.59	0.10	0.14

A detailed output including formulas is available since SCIA Engineer 20:

Scaffolding - Coupler check

Nonlinear calculation
Class: NC_ULS
Coordinate system: Principal
Extreme 1D: Global
Selection: All

EN 12811-1 Code Check

National annex: Belgian NBN-EN NA

Scaffolding Coupler	Member	Location / Length [m]	Material	Coupler type	Case	UC _{Max} [-]
H1300	S5919	0.000/5.140	Steel	Layher (Variante K2000+)	NC_ULS	0.59

Partial safety factors	
γ _{M0}	1.10

Design internal forces

		Member	Scaffolding Coupler	Unit
Normal force	N _{Ed}	14.35	14.35	kN
Shear force	V _{y,Ed}	-0.15	-0.15	kN
Shear force	V _{z,Ed}	-2.87	-2.87	kN
Torsion moment	M _{x,Ed}	0.00	0.00	kNm
Bending moment	M _{y,Ed}	0.09	0.09	kNm
Torsion moment	M _{z,Ed}	0.00	0.00	kNm

Scaffolding coupler resistances

According to Z-8.22-64:2018 Table 5

Scaffolding Coupler H1300		
N _{rk}	34.10	kN
V _{yk}	11.00	kN
V _{zk}	29.04	kN
M _{xk}	0.58	kNm
M _{yk}	1.11	kNm
M _{zk}	0.41	kNm

Scaffolding coupler check

According to EN 12811-1

Normal force check N

$$UC_{F_x} = \frac{N_{Ed}}{N_{rk}} = \frac{14.35[kN]}{34.10[kN]} = 0.46 \leq 1.00 \quad (\S 10.3.3.1)$$

Shear force check V_y

$$UC_{F_y} = \frac{V_{y,Ed}}{V_{yk}} = \frac{-0.15[kN]}{11.00[kN]} = 0.02 \leq 1.00 \quad (\S 10.3.3.1)$$

Shear force check V_z

$$UC_{F_z} = \frac{V_{z,Ed}}{V_{zk}} = \frac{-2.87[kN]}{29.04[kN]} = 0.11 \leq 1.00 \quad (\S 10.3.3.1)$$

Torsional moment check M_x

$$UC_{M_x} = \frac{M_{x,Ed}}{M_{xk}} = \frac{0.00[kNm]}{0.58[kNm]} = 0.00 \leq 1.00 \quad (\S 10.3.3.1)$$

Bending moment check M_y

$$UC_{M_y} = \frac{M_{y,Ed}}{M_{yk}} = \frac{0.09[kNm]}{1.11[kNm]} = 0.09 \leq 1.00 \quad (\S 10.3.3.1)$$

Torsional moment check M_z

$$UC_{M_z} = \frac{M_{z,Ed}}{M_{zk}} = \frac{0.00[kNm]}{0.41[kNm]} = 0.00 \leq 1.00 \quad (\S 10.3.3.1)$$

Interaction checks

According to Z-8.22-64:2018

Interaction check 1

$$UC_{Interaction1} = \frac{N_{Ed}^-}{\gamma_{M0} N_{yk}} + \frac{|M_{y,Ed}|}{\gamma_{M0} M_{yk}} + \frac{\max(|V_{z,Ed}| - V_{z,Ed,min}, 0)}{\gamma_{M0} V_{zk}} + \frac{|M_{z,Ed}|}{\gamma_{M0} M_{zk}} + \frac{|V_{y,Ed}|}{\gamma_{M0} V_{y,Rd}} + \frac{|M_{x,Ed}|}{\gamma_{M0} M_{xk}}$$

$$= \frac{14.35[kN]}{1.10 \times 34.10[kN]} + \frac{|0.09[kNm]|}{1.10 \times 1.11[kNm]} + \frac{\max(|-2.87[kN]| - 2.10[kN], 0[kN])}{1.10 \times 29.04[kN]} + \frac{|0.00[kNm]|}{1.10 \times 0.41[kNm]} + \frac{|-0.15[kN]|}{1.10 \times 27.10[kN]} + \frac{|0.00[kNm]|}{1.10 \times 0.58[kNm]} = 0.59 \leq 1.00 \quad (6)$$

Interaction check 2

$$nA = \frac{N_{Ed}^+ + \frac{|M_{y,Ed}|}{e}}{\xi \times \frac{N_{yk}}{\gamma_{M0}}} = \frac{14.35[kN] + \frac{0.09[kNm]}{33[mm]}}{1.85 \times \frac{34.10[kN]}{1.10}} = 0.30 \quad (\S 3.2.6.1 \text{ Table 11})$$

$$nB = \frac{0.707 \times \sum(\sin(\alpha) \times N_{v,Ed}^+) + \frac{eD}{e} \times \sum(\cos(\alpha) \times |N_{v,Ed}|)}{\xi \times \frac{N_{yk}}{\gamma_{M0}}} = \frac{0.707 \times 0.00[kN] + \frac{57[mm]}{33[mm]} \times 0.00[kN]}{1.85 \times \frac{34.10[kN]}{1.10}} = 0.00 \quad (\S 3.2.6.1 \text{ Table 11})$$

$$vA = \frac{V_{z,Ed}}{\gamma_{M0} V_{zk}} = \frac{-2.87[kN]}{1.10 \times 29.04[kN]} = -0.11 \quad (\S 3.2.6.1 \text{ Table 11})$$

$$vB = \frac{\sum(\cos(\alpha) \times N_{v,Ed})}{\gamma_{M0} V_{zk}} = \frac{0.00[kN]}{1.10 \times 29.04[kN]} = 0.00 \quad (\S 3.2.6.1 \text{ Table 11})$$

$$UC_{Interaction2} = (nA + nB)^2 + (vA + vB)^2 = (0.30 + 0.00)^2 + (-0.11 + 0.00)^2 = 0.10 \leq 1.00 \quad (14)$$

Interaction check 3

Column data		
Member	B122	
Section	2.000	m
N _{st,Ed}	-13.97	kN
V _{st,Ed}	0.20	kN
M _{st,Ed}	0.02	kNm
A _{st}	453	mm ²
A _{v,st}	288	mm ²
W _{el,st}	4800	mm ³
W _{pl,st}	6509	mm ³
f _{yk}	320.0	MPa

$$I_A = \frac{|M_{y,Ed}|}{\gamma_{M0} M_{yk}} = \frac{|0.09[kNm]|}{1.10 \times 1.11[kNm]} = 0.09$$

$$N_{st,Rd} = \frac{A_{st} \times f_{yk}}{\gamma_{M0}} = \frac{453[mm^2] \times 320.0[MPa]}{1.10} = 131.78[kN]$$

$$n_{act} = \frac{|N_{st,Ed}|}{N_{st,Rd}} = \frac{|-13.97[kN]|}{131.78[kN]} = 0.11$$

$$V_{st,Rd} = \frac{A_{v,st} \times f_{yk}}{\sqrt{3} \times \gamma_{M0}} = \frac{288[mm^2] \times 320.0[MPa]}{\sqrt{3.00} \times 1.10} = 48.44[kN]$$

$$v_{act} = \frac{|V_{st,Ed}|}{V_{st,Rd}} = \frac{|0.20[kN]|}{48.44[kN]} = 0.00$$

$$\alpha_{pl} = \min\left(\frac{W_{pl,st}}{W_{el,st}}, 1.25\right) = \min\left(\frac{6509[mm^3]}{4800[mm^3]}, 1.25\right) = \min(1.36, 1.25) = 1.25$$

$$M_{st,Rd} = \frac{\alpha_{pl} \times W_{el,st} \times f_{yk}}{\gamma_{M0}} = \frac{1.25 \times 4800[mm^3] \times 320.0[MPa]}{1.10} = 1.75[kNm]$$

$$m_{act} = \frac{|M_{st,Ed}|}{M_{st,Rd}} = \frac{|0.02[kNm]|}{1.75[kNm]} = 0.01$$

$$m = 0.11$$

$$n = \frac{n_{act}}{m_{act}} \times m = \frac{0.11}{0.01} \times 0.11 = 0.93$$

$$a = \sqrt{m_{act}^2 + n_{act}^2} = \sqrt{0.01^2 + 0.11^2} = 0.11$$

$$b = \sqrt{m^2 + n^2} = \sqrt{0.11^2 + 0.93^2} = 0.94$$

$$I_S = \frac{a}{b} = \frac{0.11}{0.94} = 0.11$$

$$UC_{Interaction3} = I_S + 0.316 \times I_A = 0.11 + 0.32 \times 0.09 = 0.14 \leq 1.00$$

(§ 3.2.2.2 Table 6)

Chapter 5: Reporting

5.1. Engineering report

As for other structural projects you can create an engineering report with the structural elements (nodes, elements, supports, ...), loads (load cases, combinations, ...) and results (displacements, internal forces, ...).

The scaffolding checks (member check and coupler check) can be added as well:

The screenshot shows the SCIA Engineer software interface. On the left is the 'Navigator' pane with a tree view of project elements. The 'Available items' pane in the center lists various check types, with 'Scaffolding - coupler check' highlighted in red. On the right is a report preview for 'Scaffolding training'.

Report Preview:

SCIAENGINEER
SCIA Engineer 99.01489.012

Part: -
Author: BV
Date: 02.07.2020

Project Scaffolding training

4.2. EC-EN 1993 Steel check ULS
Nonlinear calculation
Class: NC_ULS
Coordinate system: Principal
Extreme ID: Cross-section
Selection: All

EN 1993-1-1 Code Check
EN 12811-1 Scaffolding Check
National annex: Belgian NBN-EN NA

MemberB115	2.000 / 2.000 m	RO48.3X3.2	S 235_yield 320	NC_ULS	0.38 -
------------	-----------------	------------	-----------------	--------	--------

Combination key
NC_ULS / NC_CO20

Partial safety factors

γ_{M2} for resistance of cross-sections	1.10
γ_{M2} for resistance to instability	1.10
γ_{M2} for resistance of net sections	1.25

Material

Yield strength	f_y	320.0	MPa
Ultimate strength	f_u	360.0	MPa
Fabrication			Rolled

SECTION CHECK:...
The critical check is on position 2.000 m

Internal forces

Internal forces	Calculated	Unit
Normal force	N_{Ed} -17.65	kN
Shear force	V_{Ed} 0.67	kN
Shear force	V_{Ed} 0.24	kN
Torsion	T_{Ed} 0.01	kNm
Bending moment	$M_{y,Ed}$ 0.11	kNm
Bending moment	$M_{z,Ed}$ 0.64	kNm

Scaffolding check for tubular members
According to EN 12811-1:2003 article 10.3.3.2 and equation 9

Normal force resistance	$N_{pl,Rd}$	131.78	kN
Shear resistance	$V_{pl,Rd}$	48.44	kN
Bending resistance	$M_{pl,Rd}$	1.75	kNm
Unity check N		0.13	-
Unity check V		0.02	-
Unity check M		0.37	-
Unity check Interaction		0.38	-
Unity check Max		0.38	-

The member satisfies the section check.

EN 1993-1-1 Code Check
EN 12811-1 Scaffolding Check
National annex: Belgian NBN-EN NA

MemberB859	0.545 / 1.090 m	RO48.3X3.2	S 235_yield 320	NC_ULS	0.60 -
------------	-----------------	------------	-----------------	--------	--------

5.2. Pictures

It is possible to generate pictures/views based on the line grid. In that case there should be a 3D line grid in your model. You can right-click in the graphical scene, select **Image wizard** and choose **Sections by planes of linegrid (overview drawings)**.

These pictures can be added to the Engineering report as well.

Annex A: Characteristic values of the resistances for couplers

The tables and figures below are taken from EN 12811-1.

Table C.1 — Characteristic values of resistances for couplers

Coupler type	Resistance	Characteristic value				
		class A	class B		class AA	class BB
Right-angle coupler (RA)	Slipping force $F_{s,k}$ in kN	10,0	15,0		15,0	25,0
	Cruciform bending moment $M_{B,k}$ in kNm	---	0,8		---	---
	Pull-apart force $F_{p,k}$ in kN	20,0	30,0		---	---
	Rotational moment $M_{T,k}$ in kNm	---	0,13		---	---
Friction type sleeve coupler (SF)	Slipping force $F_{s,k}$ in kN	6,0	9,0		---	---
	Bending moment $M_{B,k}$ in kNm	---	2,4		---	---
Swivel coupler (SW)	Slipping force $F_{s,k}$ in kN	10,0	15,0		---	---
Parallel coupler (PA)	Slipping force $F_{s,k}$ in kN	10,0	15,0		---	---

For symbols see Figures C.3 and C.4

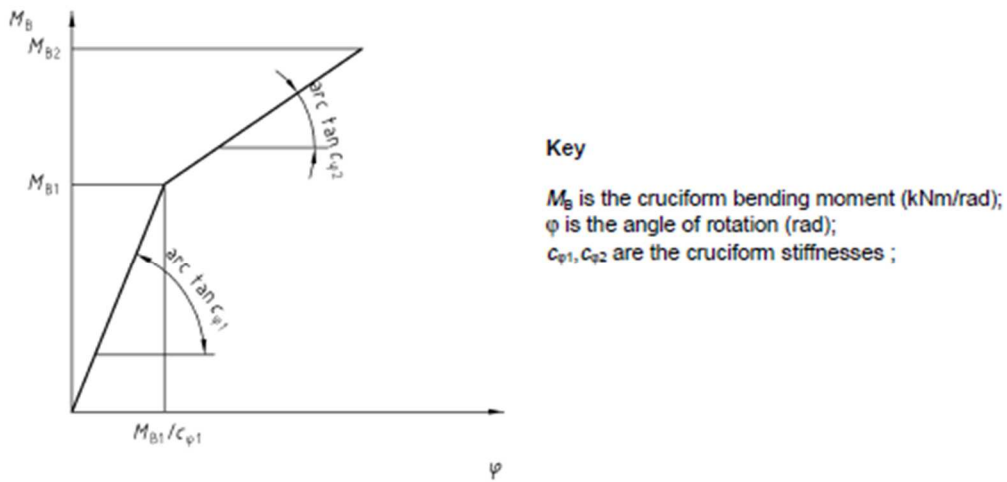

Figure C.1 — M_B - φ relationship for class B right angle couplers

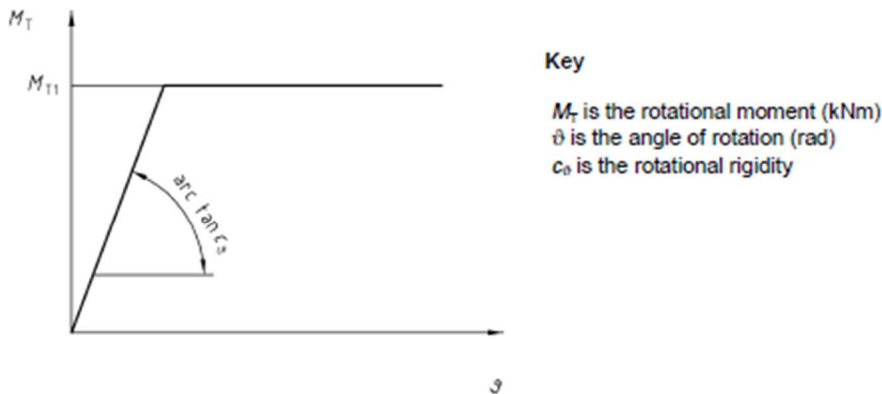

Figure C.2 — M_T - φ relationship for class B and C right angle couplers secured by screwed means

Table C.2 — Design values c_{ϕ_1} and c_{ϕ_2} of cruciform stiffnesses for class B right angle couplers attached to steel- and aluminium tubes

	Steel Tube				Aluminium tube			
	c_{ϕ_1} [kNm/rad]	M_{B1} [kNm]	c_{ϕ_2} [kNm/rad]	M_{B2} [kNm]	c_{ϕ_1} [kNm/rad]	M_{B1} [kNm]	c_{ϕ_2} [kNm/rad]	M_{B2} [kNm]
	15,0	0,48	6,0	0,8	13,0	0,48	5,0	0,8
For symbols see Figure C.1								

Table C.3 — Design values c_0 of rotational stiffness for class B right angle couplers

	c_0 [kNm/rad]	M_{T1} [kNm]
	7,5	0.13
For symbols see Figure C.2		

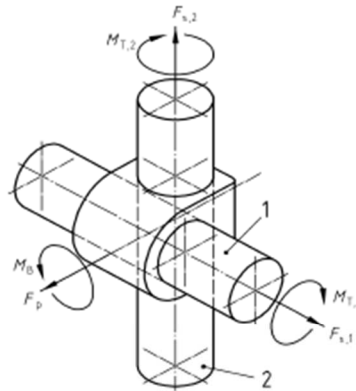

Key

- 1 tube 1
- 2 tube 2
- s slipping force
- p pull apart force
- B cruciform bending moment
- T rotational moment

Figure C.3 - Loads on a right-angle coupler

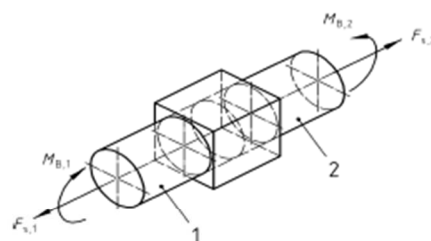

Key

- 1 tube 1
- 2 tube 2
- s slipping force
- B bending moment

Figure C.4 - Loads on a friction type sleeve coupler

Annex B: Service loads according to EN 12811-1

The service loads are considered in table 3 of EN 12811-1:

Table 3 — Service loads on working areas (see also 6.2.2)

Load class	Uniformly distributed load q_1 kN/m ²	Concentrated load on area 500 mm x 500 mm F_1 kN	Concentrated load on area 200 mm x 200 mm F_2 kN	Partial area load	
				q_2 kN/m ²	Partial area factor a_p ¹
1	0,75 ²	1,50	1,00	---	---
2	1,50	1,50	1,00	---	---
3	2,00	1,50	1,00	---	---
4	3,00	3,00	1,00	5,00	0,4
5	4,50	3,00	1,00	7,50	0,4
6	6,00	3,00	1,00	10,00	0,5

Uniformly distributed service load q_1 (EN 12811-1, 6.2.2.2)

Each working area is capable of supporting the uniformly distributed loads, q_1 as specified in the table above.

Concentrated load F_1 and F_2 (EN 12811-1, 6.2.2.3)

Each platform unit is capable of supporting the load F_1 uniformly distributed over an area of 500 mm x 500 mm and, but not simultaneously, F_2 uniformly distributed over an area of 200 mm x 200 mm.

The position of each load is chosen to give the most unfavourable effect.

When a platform unit is less than 500 mm wide, the load may be reduced for this unit in proportion to its width, except that in no case shall the loading be reduced to less than 1.5 kN.

Partial area load q_2 (EN 12811-1, 6.2.2.4)

This load has to be applied only for classes 4, 5 and 6. In those cases each platform is capable of supporting a partial area loading q_2 on an area A_{q_2} :

$$A_{q_2} = l \cdot w \cdot a_p$$

With:

- l length
- w width
- a_p coefficient of table 3

The dimensions and position of the partial area are chosen to give the most unfavourable effect. One example is shown below:

M max; δ : max

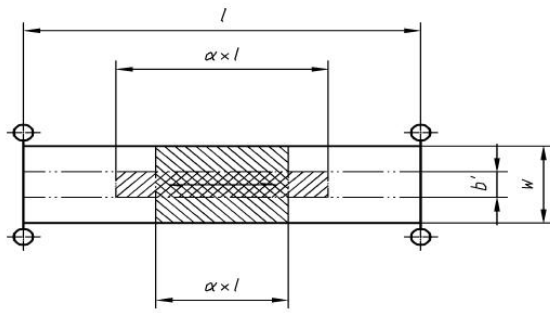

V max

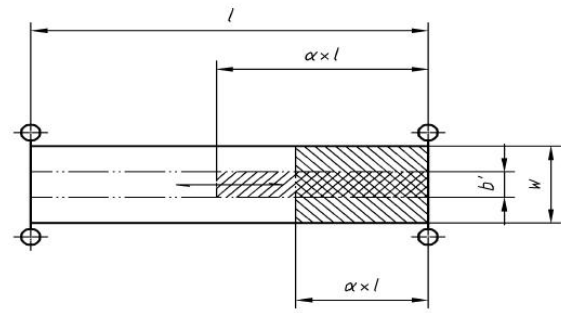

$$b' \leq a_p \times w: \quad \alpha = 1$$

$$a_p \times w \leq b' \leq w: \quad \alpha = a_p \times \frac{w}{b'}$$

Annex C: Wind loads

Since the arithmetic method for the calculation of a wind load from code EN 12811-1 is not valid for all scaffoldings, provided by nets that completely surround the construction, the code EN 1991-1-4 is adopted.

There are three cases for calculating a reference height (EN 1991-1-4, figure 7.4):

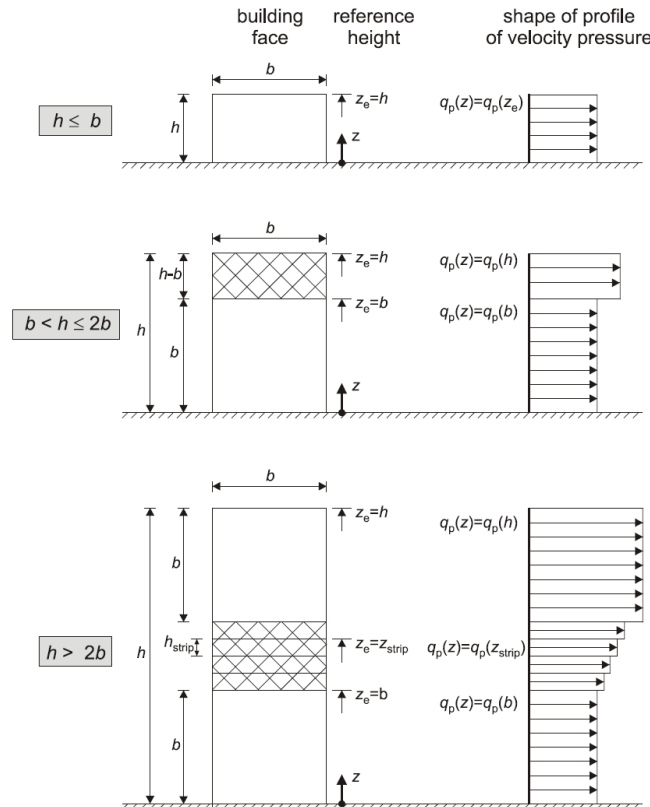

In the example discussed in this course, the height is 20 m and the building face is 29.84 m. So in this case clearly $20 \text{ m} \leq 29.84 \text{ m}$ and thus $h \leq b$. So the wind only has to be calculated for $z_e = 20 \text{ m}$.

In this example, the wind is calculated for a construction without 50% nets, situated in Belgium for terrain category IV, wind zone 25 m/s and reference period 15 years.

The terrain category is determined as follows (EN 1991-1-4, Table 4.1):

Terrain category		z_0 m	z_{min} m
0	Sea or coastal area exposed to the open sea	0,003	1
I	Lakes or flat and horizontal area with negligible vegetation and without obstacles	0,01	1
II	Area with low vegetation such as grass and isolated obstacles (trees, buildings) with separations of at least 20 obstacle heights	0,05	2
III	Area with regular cover of vegetation or buildings or with isolated obstacles with separations of maximum 20 obstacle heights (such as villages, suburban terrain, permanent forest)	0,3	5
IV	Area in which at least 15 % of the surface is covered with buildings and their average height exceeds 15 m	1,0	10

For Belgium, $v_{b,0}$ equals 25 m/s following the EC-EN. In addition c_{dir} and c_{season} are all equal to 1.0. From this the basic wind velocity v_b can be calculated with formula (4.1) of EN 1991-1-4:

$$v_b = c_{dir} \cdot c_{season} \cdot v_{b,0} \cdot c_{prob} = 1.0 \cdot 1.0 \cdot 25 \cdot 0.928 = 23.21 \text{ m/s}$$

- c_{dir} directional factor: value may be given in the National Annex, recommended value 1.0
- c_{season} season factor: value may be given in the National Annex, recommended value 1.0
- $c_{prob} = \left(\frac{1-K \cdot \ln(-\ln(1-p))}{1-K \cdot \ln(-\ln(0.98))} \right)^n = \left(\frac{1-0.2 \cdot \ln(-\ln(1-0.067))}{1-0.2 \cdot \ln(-\ln(0.98))} \right)^{0.5} = 0.928$
- R reference period $\rightarrow p = 1/R$

For terrain category IV, the mean wind velocity v_m is calculated using the following formula (4.3) of EN 1991-1-4:

$$v_m(z) = c_r(z) \cdot c_0(z) \cdot v_b$$

- $c_r(z) = k_r \cdot \ln\left(\frac{z}{z_0}\right)$ for $z_{min} \leq z \leq z_{max}$
- $c_r(z) = c_r(z_{min})$ for $z \leq z_{min}$
- c_0 orography factor: taken as 1.0, unless specified otherwise in EN 1991-1-4 §4.3.3
- $k_r = 0.19 \cdot \left(\frac{z_0}{z_{0,II}}\right)^{0.07}$

For our example:

$$v_m(z) = 0.19 \cdot \left(\frac{z_0}{z_{0,II}}\right)^{0.07} \cdot \ln\left(\frac{z}{z_0}\right) \cdot c_0(z) \cdot v_b = 0.19 \cdot \left(\frac{1.0}{0.05}\right)^{0.07} \cdot \ln\left(\frac{20}{1.0}\right) \cdot 1.0 \cdot 23.21 = 16.29 \text{ m/s}$$

The peak velocity pressure is calculated with formula (4.8) of EN 1991-1-4:

$$q_p(z) = c_e(z) \cdot q_b = c_e(z) \cdot \frac{1}{2} \cdot \rho \cdot v_b^2$$

- ρ 1.25 kg/m³
- $c_e(z) = [1 + 7 \cdot I_v(z)] \cdot (c_r(z))^2 \cdot (c_0(z))^2$
- $I_v(z) = \frac{k_1}{c_0(z) \cdot \ln\left(\frac{z}{z_0}\right)}$ for $z_{min} \leq z \leq z_{max}$
- $I_v(z) = I_v(z_{min})$ for $z \leq z_{min}$
- k_1 turbulence factor: value may be given in the National Annex (0.85 for terrain category IV according to NBN EN 1991-1-4)

For our example the **maximal wind pressure** will become:

$$q_p(z) = \left[1 + 7 \cdot \frac{k_1}{c_0(z) \cdot \ln\left(\frac{z}{z_0}\right)} \right] \cdot (c_r(z))^2 \cdot (c_0(z))^2 \cdot \frac{1}{2} \cdot \rho \cdot v_b^2 = \left[1 + 7 \cdot \frac{k_1}{c_0(z) \cdot \ln\left(\frac{z}{z_0}\right)} \right] \cdot \frac{1}{2} \cdot \rho \cdot v_m^2$$

$$q_p(z) = \left[1 + 7 \cdot \frac{0.85}{1.0 \cdot \ln\left(\frac{20}{0.3}\right)} \right] \cdot \frac{1}{2} \cdot 1.25 \cdot 16.29^2 = 496 \text{ N/m}^2 = 0.496 \text{ kN/m}^2$$

EN 12811-1 §6.2.7.4.2 prescribes that if the scaffolding is into service, it only needs to be loaded with the so-called working wind load: a uniformly distributed velocity pressure of 0.20 kN/m² shall be taken into account.

This working wind load is calculated analogously to the maximal wind load on the scaffolding, but a reference wind pressure of 0.20 kN/m² is assumed:

Annex D: Stability analysis

Linear Stability

During a linear stability calculation, the following assumptions are used:

- Physical Linearity.
- The elements are taken as ideally straight and have no imperfections.
- The loads are guided to the mesh nodes, it is thus mandatory to refine the finite element mesh in order to obtain precise results.
- The loading is static.
- The critical load coefficient is, per mode, the same for the entire structure.
- Between the mesh nodes, the axial forces and moments are taken as constant.

The equilibrium equation can be written as follows:

$$[K_E - K_G] \cdot u = F$$

The symbol u depicts the displacements and F is the force matrix.

As specified in the theory of the Timoshenko method, the stiffness K is divided in the elastic stiffness K_E and the geometrical stiffness K_G . The geometrical stiffness reflects the effect of axial forces in beams and slabs.

The basic assumption is that the elements of the matrix K_G are linear functions of the axial forces in the members. This means that the matrix K_G corresponding to a λ^{th} multiple of axial forces in the structure is the λ^{th} multiple of the original matrix K_G .

The aim of the buckling calculation is to find such a multiple λ for which the structure loses stability. Such a state happens when the following equation has a non-zero solution:

$$[K_E - \lambda \cdot K_G] \cdot u = 0$$

In other words, such a value for λ should be found for which the determinant of the total stiffness matrix is equal to zero:

$$K_E - \lambda \cdot K_G = 0$$

Similar to the natural vibration analysis, the subspace iteration method is used to solve this eigenmode problem. As for a dynamic analysis, the result is a series of **critical load coefficients** λ with corresponding eigenmodes.

To perform a stability calculation, the functionality **Stability** must be activated.

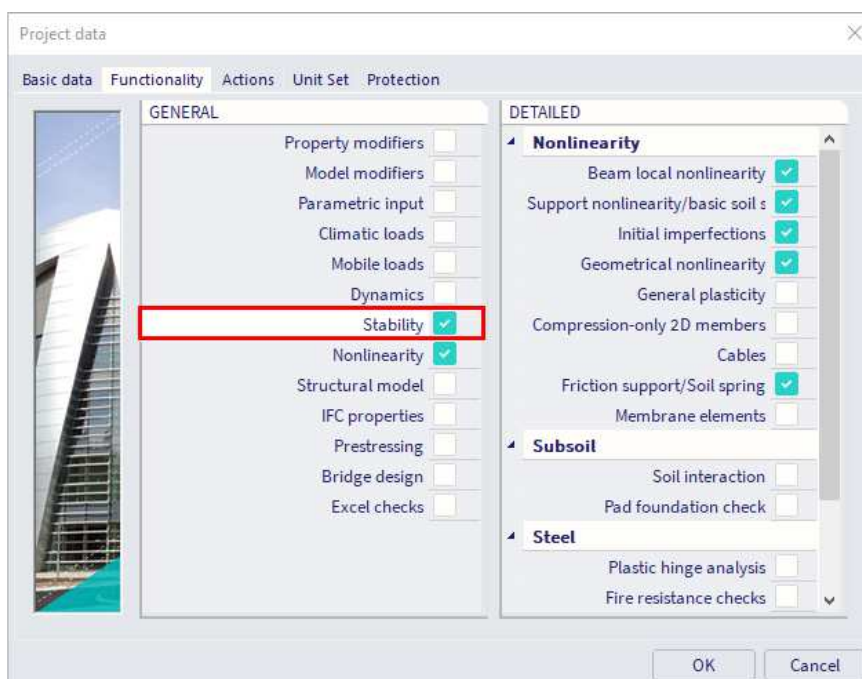

The λ values can be found under **Results > Critical load coefficients**.

The number of critical coefficients to be calculated per stability combination can be specified under **Setup > Solver**.

Notes:

- The first eigenmode is usually the most important and corresponds to the lowest critical load coefficient. A possible collapse of the structure usually happens for this first mode.
- The structure becomes unstable for the chosen combination when the loading reaches a value equal to the current loading multiplied with the critical load factor.
- A critical load factor smaller than 1 signifies that the structure is unstable for the given loading.
- The eigenmodes (buckling shapes) are dimensionless. Only the relative values of the deformations are of importance, the absolute values have no meaning.
- 'Initial Stress' is the only local nonlinearity taken into account in a linear stability calculation.

The principle of a stability calculation and the meaning of the matrix \mathbf{K}_G will be explained with a simple example. Suppose the next situation:

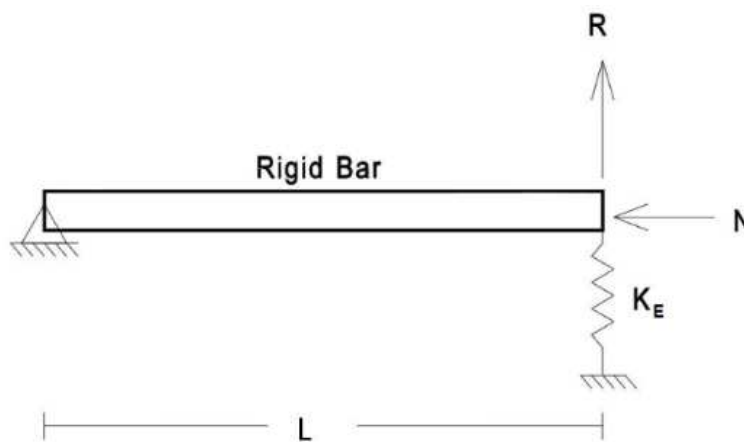

This beam with length L has a pinned support at the left and a flexible spring support at the right with rigidity: K_E . Two point loads are inputted on the beam: a vertical force R and a compression force N .

Standard analysis says that R and N are independent (in the undeformed configuration) and the stiffness relationship is:

$$K_E \cdot r = R$$

With r the vertical translation of the right point of the beam.

But, if the structure is allowed to deform, we can calculate equilibrium in the deformed configuration as shown below:

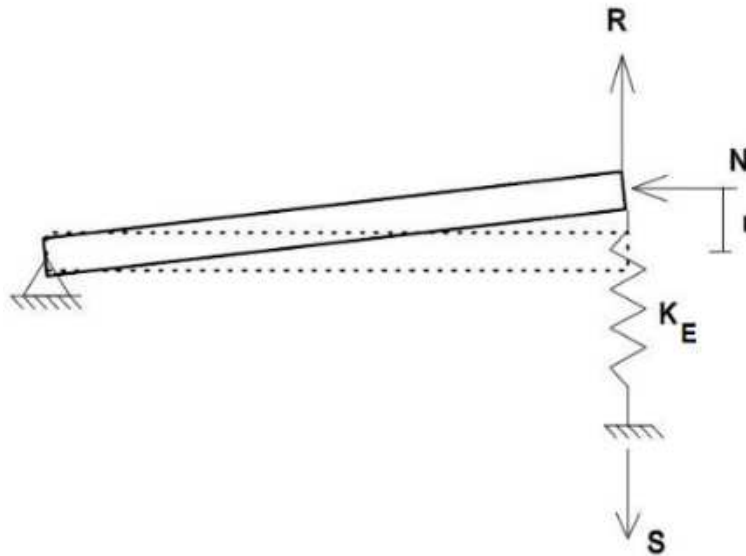

Summing moments about the pinned end we get:

$$R \cdot L + N \cdot r = S \cdot L$$

The equation for the response of the spring is:

$$K_E \cdot r = S$$

Substituting S we get:

$$R \cdot L + N \cdot r = (K_E \cdot r) \cdot L$$

Dividing by L:

$$R + \frac{N}{L} \cdot r = K_E \cdot r$$

And grouping terms we have:

$$R = \left(K_E - \frac{N}{L} \right) \cdot r$$

This can further be rewritten if we define the geometric stiffness as:

$$K_G = \frac{N}{L}$$

giving the final form as:

$$R = (K_E - K_G) \cdot r$$

Or:

$$[K_E - K_G] \cdot u = F$$

When the normal force **N** is multiplied with a factor α_{cr} so that the total rigidity becomes zero:

$$K_E - \frac{\alpha_{cr} \cdot N}{L} = 0$$

The structure will buckle and become 'unstable'.

Nonlinear Stability

As specified in the assumptions of the previous paragraph: a stability calculation is by default a linear process. Nonlinearities like friction supports, pressure only supports, ... are not taken into account.

Specifically for this purpose, SCIA Engineer provides the use of a nonlinear stability calculation. This type of calculation has the following additions to the linear stability calculation:

- local nonlinearities are taken into account;
- 3rd order effects are taken into account using the Modified Newton-Raphson algorithm.

Modified Newton-Raphson follows the same principles as the default method but will automatically refine the number of increments when a critical point is reached and will only update its stiffness matrix every N iterations. This method can therefore give precise results for post-critical states.

SCIA Engineer will perform a 3rd Order calculation considering local nonlinearities. After this calculation, the resulting deformed structure is used for a stability calculation. As a result, the critical load factor of the structure is obtained for the structure including nonlinearities.

To activate the nonlinear stability calculation, the functionalities **Stability** and **Nonlinearity > Geometrical nonlinearity** must be activated.

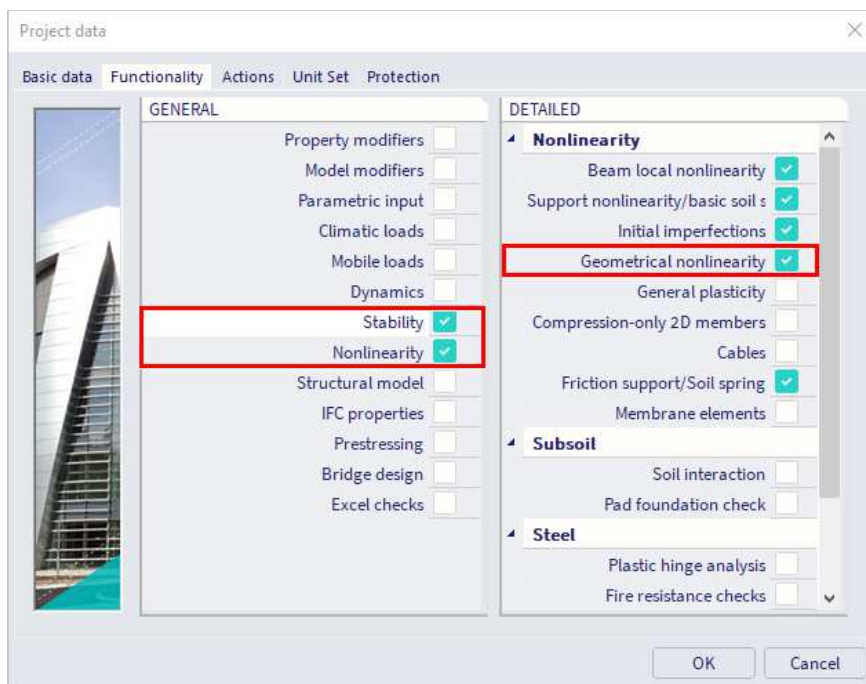

In addition, support and/or beam local nonlinearities can also be activated.

The choice of the 3rd order theory, the amount of increments and the maximal amount of iterations can be specified through Menu bar > Tools > **Calculation & Mesh** > **Solver settings**:



Since the nonlinear stability calculation automatically implies the Modified Newton-Raphson method for the solver, this method cannot be chosen here. The reason why this field is available is to perform a normal 3rd Order Calculation using Modified Newton-Raphson instead of a stability calculation.

Since the Modified Newton-Raphson method also applies the loading using increments, it is important to set a right amount of increments. This implies that it is advised to choose the Newton-Raphson method so you have access to the number of increments.

Buckling shape

► Example Stability_Imperfection.esa

In this example, the use of the buckling shape as imperfection according to EC3 is illustrated for a column.

The column has a cross-section of type **RO48,3X3,2**, is fabricated from **S 235** and has the following relevant properties:

- $E = 210.000 \text{ N/mm}^2$
- $f_y = 235 \text{ N/mm}^2$
- $\gamma_{M1} = 1,00$
- $L = 2000 \text{ mm}$
- $A = 453 \text{ mm}^2$
- $I_y = 116000 \text{ mm}^4$
- $W_{pl,y} = 6508.8 \text{ mm}^3$

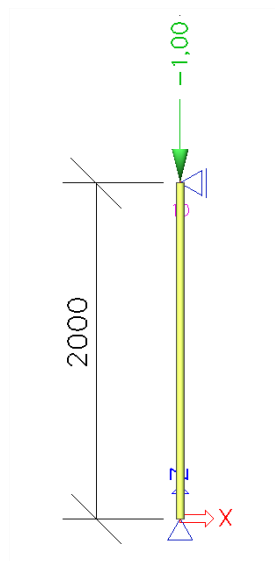

Calculation of the buckling shape

First a **stability calculation** is done using a load of 1 kN. This way, the elastic critical buckling load N_{cr} is obtained. In order to obtain precise results, the **Number of 1D elements** is set to **10**. In addition, the **Shear Force Deformation** is neglected so the result can be checked by a manual calculation.

The stability calculation gives the following result:

Critical load coefficients	
N	f
-	□
Stability combination : S1	
1	60,11

This can be verified with Euler's formula using the member length as the buckling length:

$$N_{cr} = \frac{\pi^2 EI}{l^2} = \frac{\pi^2 \cdot 210.000 \frac{\text{N}}{\text{mm}^2} \cdot 116000 \text{ mm}^4}{(2000 \text{ mm})^2} = 60105,89 \text{ N}$$

The following picture shows the mesh nodes of the column and the corresponding buckling shape:

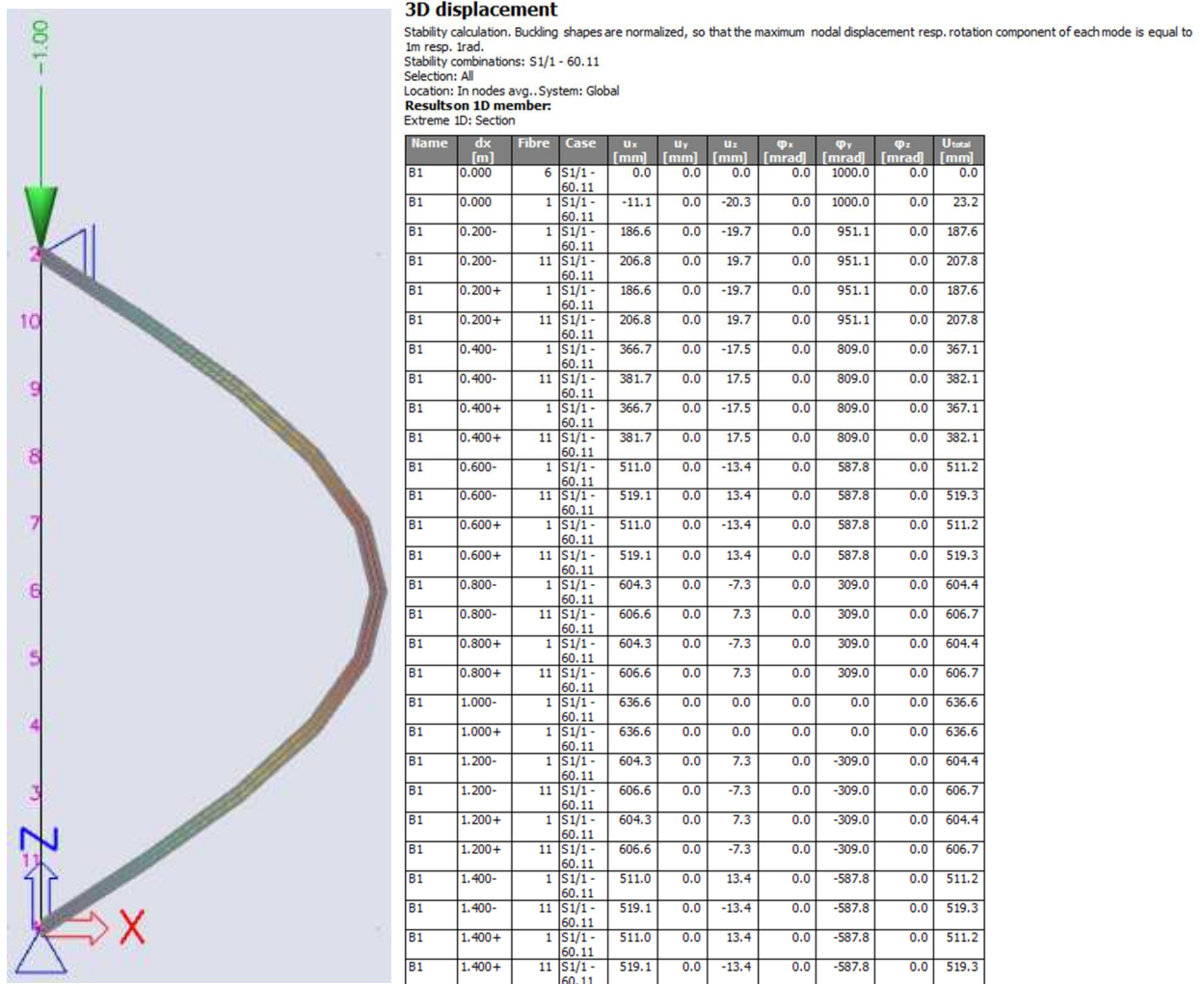

Using for example an Excel worksheet, the buckling shape can be approximated by a 4th grade polynomial.

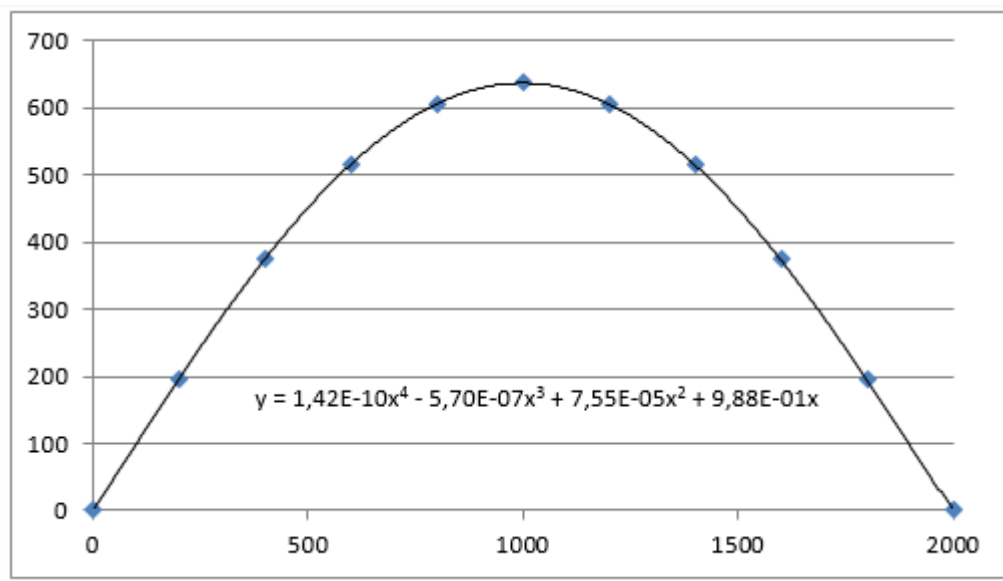

A polynomial has the advantage that the second derivative can easily be calculated:

$$\Rightarrow \eta_{cr} = 1,42E-10 x^4 - 5,70E-07 x^3 + 7,55E-05 x^2 + 9,88E-01 x$$

$$\Rightarrow \eta''_{cr,max} = 1,70E-09 x^2 - 3,43E-06 x + 1,51E-4$$

Calculation of e_0

$$N_{Rk} = f_y \cdot A = 235 \text{ N/mm}^2 \cdot 453 \text{ mm}^2 = 106455 \text{ N}$$

$$M_{Rk} = f_y \cdot W_{pl} = 235 \text{ N/mm}^2 \cdot 6508.8 \text{ mm}^3 = 1529568 \text{ Nmm}$$

$$\bar{\lambda} = \sqrt{N_{Rk}/N_{cr}} = \sqrt{106455 \text{ N}/60110 \text{ N}} = 1,33$$

$\alpha = 0,21$ for buckling curve a

$$\chi = \frac{1}{0,5 \left[1 + \alpha(\bar{\lambda} - 0,2) + (\bar{\lambda})^2 \right] + \sqrt{\left(0,5 \left[1 + \alpha(\bar{\lambda} - 0,2) + (\bar{\lambda})^2 \right] \right)^2 - (\bar{\lambda})^2}} = 0,45$$

These intermediate results can be verified through SCIA Engineer when performing a steel ULS check on the column:

Buckling parameters		yy	zz	
Sway type		sway	non-sway	
System length	L	2.000	2.000	m
Buckling factor	k	1.00	1.00	
Buckling length	l_{cr}	2.000	2.000	m
Critical Euler load	N_{cr}	60.11	60.11	kN
Slenderness	λ	124.98	124.98	
Relative slenderness	λ_{rel}	1.33	1.33	
Limit slenderness	$\lambda_{rel,0}$	0.20	0.20	
Buckling curve	a	a	a	
Imperfection	α	0.21	0.21	
Reduction factor	χ	0.45	0.45	
Buckling resistance	$N_{b,Rd}$	48.27	48.27	kN

$$\Rightarrow e_0 = \alpha \cdot (\bar{\lambda} - 0,2) \cdot \frac{M_{Rk}}{N_{Rk}} \cdot \frac{1 - \chi \cdot (\bar{\lambda})^2}{1 - \chi \cdot (\bar{\lambda})^2} = 0,21 \cdot (1,33 - 0,2) \cdot \frac{1529568 \text{ Nmm}}{106455 \text{ N}} = 3,41 \text{ mm}$$

The required parameters have now been calculated so in the final step the amplitude of the imperfection can be determined.

Calculation of η_{init}

The mid section of the column is decisive $\Rightarrow x = 1000$

$$\eta_{cr} \text{ at mid section} = 636,6$$

$$\eta_{cr,max}'' \text{ at mid section} = 1,57E-03 \text{ 1/mm}^2$$

$$\Rightarrow \eta_{init} = e_0 \cdot \frac{N_{cr}}{E \cdot I_y \cdot \eta_{cr,max,cr}''} = 3,41 \text{ mm} \cdot \frac{60110 \text{ N}}{210000 \text{ N/mm}^2 \cdot 116000 \text{ mm}^4 \cdot 1,57E-3 \text{ 1/mm}^2} \cdot 636,6 = 3,42 \text{ mm}$$

This value can now be inputted as amplitude of the buckling shape for imperfection.

To illustrate this, the column is loaded by a compression load equal to its buckling resistance.

However, due to the imperfection, an additional moment will occur which will influence the section check. The buckling resistance can be calculated as follows:

$$N_{Ed} = N_{b,Rd} = \frac{\chi \cdot A \cdot f_y}{\gamma_{M1}} = 0,45 \cdot 453 \text{ mm}^2 \cdot 235 \text{ N/mm}^2 = 47,90 \text{ kN}$$

A nonlinear combination is created in which the buckling shape as imperfection is specified:

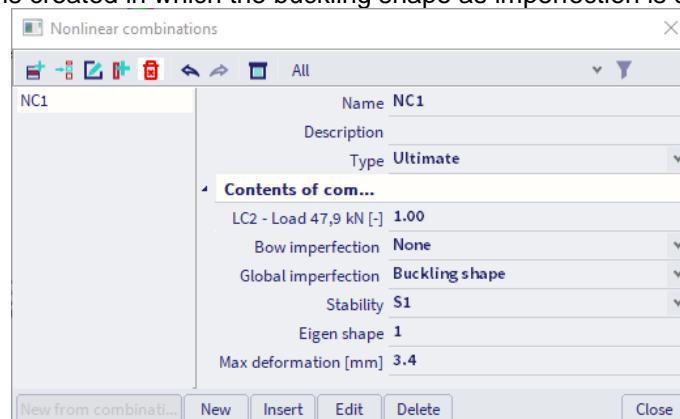

Using this combination, a nonlinear **second order** calculation is executed using **Timoshenko’s method**.

The additional moment can be easily calculated as follows:

$$M_{\eta,init} = N_{Ed} \cdot \eta_{init} \cdot \frac{1}{1 - \frac{N_{Ed}}{N_{cr}}} = 47,90 \text{ kN} \cdot 0,00342 \text{ m} \cdot \frac{1}{1 - \frac{47,90 \text{ kN}}{60,11 \text{ kN}}} = \mathbf{0,80 \text{ kNm}}$$

When performing a steel ULS check on the column for the nonlinear combination, this can be verified. The critical check is performed at **1 m** and has the following effects:

.....SECTION CHECK:.....

The critical checkis on position 1.000 m

Internalforces		Calculated	Unit
Normal force	N_{Ed}	-47.90	kN
Shear force	$V_{y,Ed}$	0.00	kN
Shear force	$V_{z,Ed}$	0.04	kN
Torsion	T_{Ed}	0.00	kNm
Bending moment	$M_{y,Ed}$	0.80	kNm
Bending moment	$M_{z,Ed}$	0.00	kNm

The additional moment thus corresponds to the moment calculated by SCIA Engineer.

As seen in the diagram of EC-EN, **Path 3** is followed: the buckling shape serves as a unique global and local imperfection. This implies that only a section check and Lateral Torsional Buckling need to be checked. Since LTB is negligible with this small bending moment, only a section check is required:

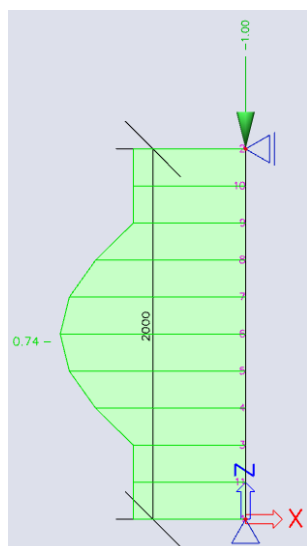

Scaffolding check for tubular members

According to EN 12811-1:2003 article 10.3.3.2and equation 9

Normal force resistance	$N_{pl,d}$	106.45	kN
Shear resistance	$V_{pl,d}$	39.13	kN
Bending resistance	$M_{pl,d}$	1.41	kNm
Unity check N		0.45	-
Unity check V		0.00	-
Unity check M		0.57	-
Unity check Interaction		0.74	-
Unity check Max		0.74	-

The member satisfies the section check.

This example has illustrated the use of a buckling shape as imperfection. Depending on the geometry of the structure, this imperfection can have a large influence on the results due to the additional moments which occur.

When using this method, it is very important to double check all applied steps: small changes to the loading or geometry require a re-calculation of the buckling shape and amplitude before a nonlinear analysis may be carried out.

As a final note: the buckling shape only gives information about a specific zone of the structure. The imperfection is applied at that zone and results/checks are only significant for that zone. Other combinations of loads will lead to another buckling shape thus to each load combination a specific buckling shape must be assigned and a steel code check should only be used on those members on which the imperfection applies. Since the applied buckling shape corresponds to a global mode, failure of these members will lead to a collapse of the structure.

References and literature

- [1] DIN 4420 Teil 1
Arbeits- und Schutzgerüste
Allgemeine Regelungen, Sicherheitstechnische Anforderungen, Prüfungen
December 1990
- [2] HD 1000
Gevelsteigers bestaande uit prefab onderdelen
1992
- [3] EN 12810-1
Façade scaffolds made of prefabricated components:
Part 1: Products specifications
2004
- [4] EN 12810-2
Façade scaffolds made of prefabricated components:
Part 2: Particular methods of structural design
2004
- [5] EN 12811-1
Temporary works equipment
Part 1: Scaffolds – performance requirements and general design
2004
- [6] EN 12811-3: Scaffolds: Load Testing, 2003
- [7] EN 12812
Falsework – Performance requirements and general design
2004
- [8] NBN ENV 1991-2-4
Belasting op draagsystemen: Windbelasting
1995
- [9] Eurocode 3:
Design of Steel Structures
Part 1 – 1 : General rules and rules for buildings
EN 1993-1-1:2003, 2003
- [10] Handbuch des Gerüstbaus
Friedrich Nather, Hoachim Lindner, Robert Hertle
2005
- [11] Eurocode 9
Design of aluminium structures
Part 1 – 1 : General structural rules
EN 1999-1-1:2007

- [12] Zulassung Nr. Z-8.22-208
Modulsystem "CUPLOK"
Deutsches Institut für Bautechnik, 2006

- [13] Zulassung Nr. Z-8.22-64
Modulsystem "Layher-Allround"
Deutsches Institut für Bautechnik, 2008

- [14] Zulassung Nr. Z-8.22-939
Modulsystem "Layher-Allround LW"
Deutsches Institut für Bautechnik, 2013

- [15] Modeling – Geometric Stiffness – $P - \Delta$

- [16] Höglund T., Beams-Columns, Alternative Imperfection according to Eurocode 9, 2005

- [17] Nederlandse Annex voor windbelasting op steigers – aanvulling op NEN-EN 1991-1-4
VSB.01.A.2020
September 2020